

## Sliding-gate operators

FA02258-EN

CE

EAC

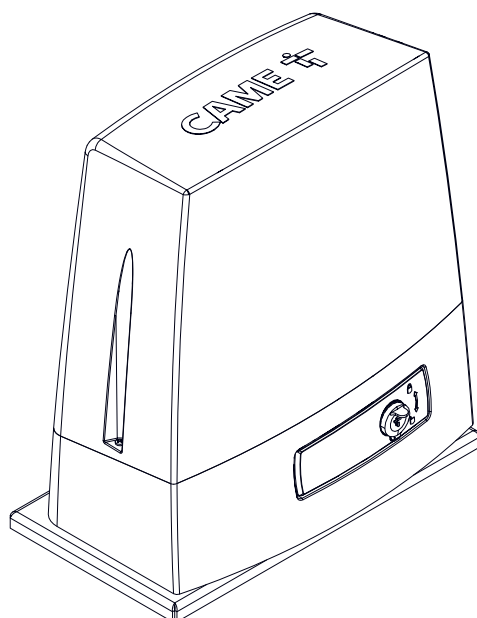

**BKX12AGM**

**BKX12RGM**

INSTALLATION MANUAL

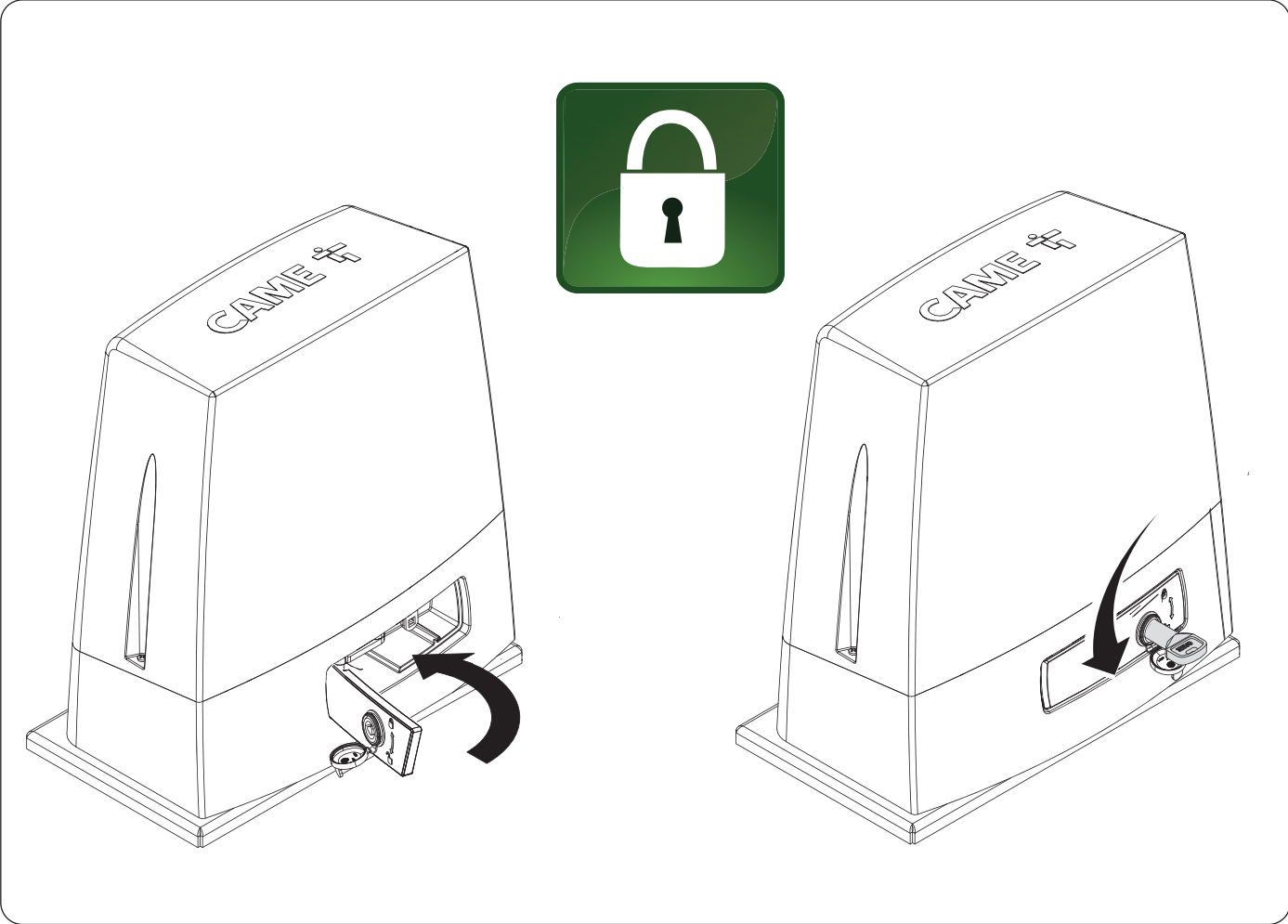
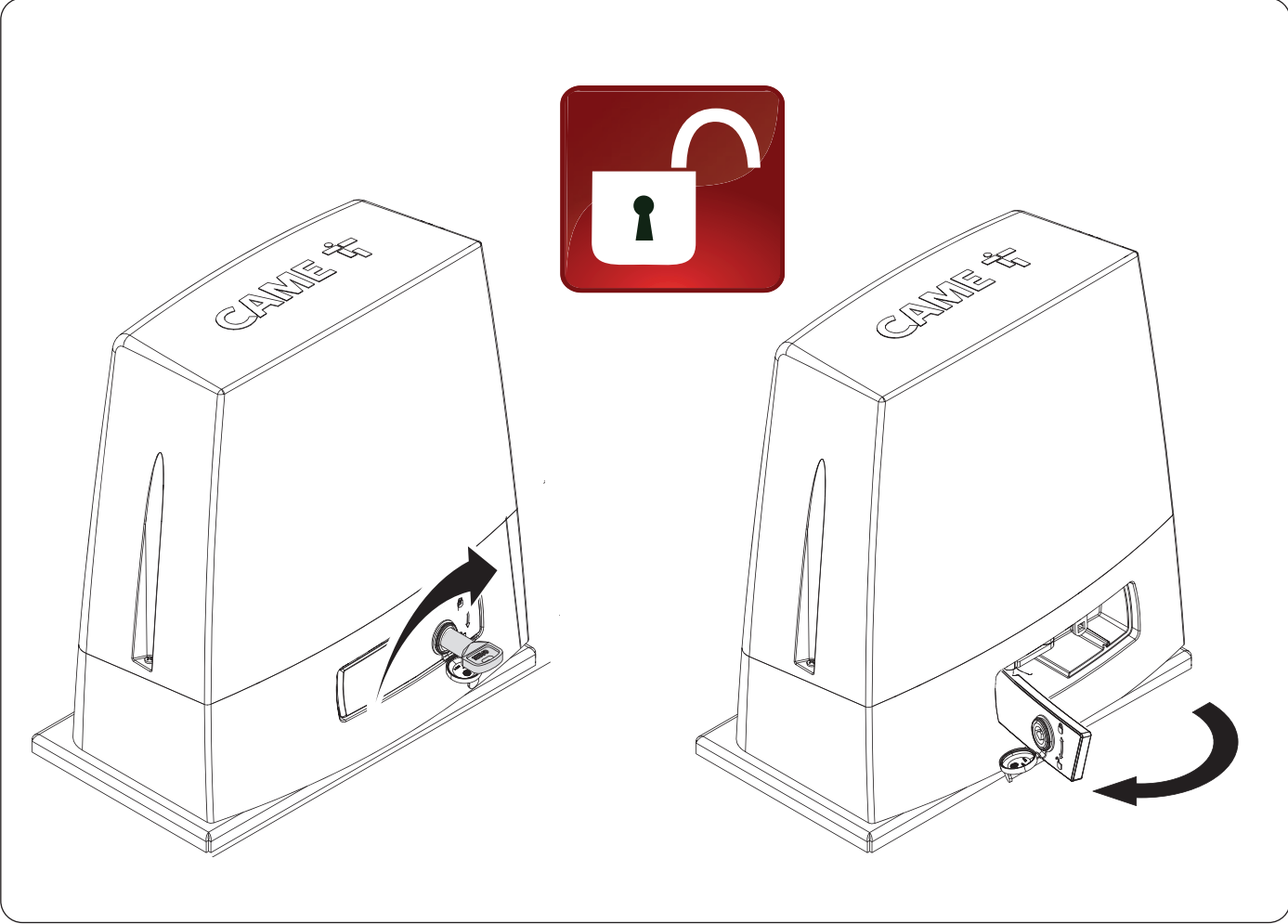

## TABLE OF CONTENTS

<b>GENERAL PRECAUTIONS</b> .....	<b>5</b>
Main points of danger for people.....	6
<b>DISMANTLING AND DISPOSAL</b> .....	<b>6</b>
<b>PRODUCT DATA AND INFORMATION</b> .....	<b>7</b>
Key .....	7
Description .....	7
Intended use.....	7
Fuse table.....	7
Description of parts .....	8
Operator.....	8
Control board ZBB3.....	9
Remove the cover .....	10
Size .....	10
Usage limitations .....	11
Technical data .....	11
Operating cycles.....	11
Cable types and minimum thicknesses .....	12
<b>INSTALLATION</b> .....	<b>13</b>
Preliminary operations.....	13
Laying the anchoring plate.....	13
Setting up the operator .....	15
Fastening the rack .....	16
Adjusting the pinion-rack coupling.....	17
Fastening the operator in place.....	17
Establishing the travel end points with magnetic limit switches .....	18
<b>ELECTRICAL CONNECTIONS</b> .....	<b>20</b>
Passing the electrical cables.....	20
Connecting to the electrical network.....	21
Power supply 230/120 V AC - 50/60 Hz.....	21
<b>Connecting accessories</b> .....	<b>21</b>
Power supply output for accessories 24 V .....	21
CXN BUS connection .....	21
Auxiliary connection output.....	21
<b>Connecting accessories with BUS CXN system</b> .....	<b>22</b>
Cabling .....	22
Cable types and minimum thicknesses.....	22
Maximum number of devices that can be connected, by type .....	22
BUS CXN device consumption.....	22
<b>Command and control devices</b> .....	<b>23</b>
<b>Signalling devices</b> .....	<b>24</b>
<b>Photocells and sensitive edges</b> .....	<b>24</b>
DIR photocells .....	24
DXR / DLX photocells .....	25
DFWN sensitive edge .....	25
<b>PROGRAMMING</b> .....	<b>26</b>
Programming button functions.....	26
Getting started.....	26
<b>FUNCTIONS MENU</b> .....	<b>26</b>
Forgotten password.....	44
Factory reset .....	44

Saving a new user ..... 45

Removing a registered user ..... 45

Change a command assigned to a user ..... 46

Creating a new timer ..... 47

Import/export data ..... 48

**PAIRED OPERATION ..... 49**

    Electrical connections ..... 49

    Programming ..... 49

    Saving users ..... 49

    Operating modes ..... 49

**DISPLAY WARNINGS KEY ..... 50**

**ERROR MESSAGES ..... 52**

**MCBF ..... 53**

**FINAL OPERATIONS ..... 53**

### **⚠ Important safety instructions.**

**⚠ Please follow all of these instructions. Improper installation may cause serious bodily harm.**

**⚠ Before continuing, please also read the general precautions for users.**

Only use this product for its intended purpose. Any other use is hazardous.

- The manufacturer cannot be held liable for any damage caused by improper, unreasonable or erroneous use.
- This product is defined by the Machinery Directive (2006/42/EC) as partly completed machinery.
- Partly completed machinery means an assembly which is almost machinery but which cannot in itself perform a specific application.
- Partly completed machinery is only intended to be incorporated into or assembled with other machinery or other partly completed machinery or equipment thereby forming machinery to which the Machinery Directive (2006/42/EC) applies.
- The final installation must comply with the Machinery Directive (2006/42/EC) and the European reference standards in force.
- The manufacturer declines any liability for using non-original products, which would also void the warranty.
- All operations indicated in this manual must be carried out exclusively by skilled and qualified personnel and in full compliance with the regulations in force.
- The device must be installed, wired, connected and tested according to good professional practice, in compliance with the standards and laws in force.
- Make sure the mains power supply is disconnected during all installation procedures.
- Check that the temperature ranges given are suitable for the installation site.
- Do not install on slopes i.e. any surfaces that are not perfectly level.
- Do not install the operator on surfaces that could yield and bend. If necessary, add suitable reinforcements to the anchoring points.
- Make sure that no direct jets of water can wet the product at the installation site (sprinklers, water cleaners, etc.).
- Make sure you have set up a suitable dual-pole cut-off device along the power supply that is compliant with the installation rules. It should completely cut off the power supply according to category III surcharge conditions.
- Demarcate the entire site properly to prevent unauthorised personnel from entering, especially minors.
- In case of manual handling, have one person for every 20 kg that needs hoisting; for non-manual handling, use proper hoisting equipment in safe conditions.
- Use suitable protection to prevent any mechanical hazards due to persons loitering within the operating range of the operator.
- The electrical cables must pass through special pipes, ducts and cable glands in order to guarantee adequate protection against mechanical damage.
- The electrical cables must not touch any parts that may overheat during use (such as the motor and transformer).
- Before installation, check that the guided part is in good mechanical condition, and that it opens and closes correctly.
- The product cannot be used to automate any guided part that includes a pedestrian gate, unless it can only be enabled when the pedestrian gate is secured.
- Make sure that nobody can become trapped between the guided and fixed parts, when the guided part is set in motion.
- Use additional protection to prevent your fingers from being crushed between the pinion and rack.
- All fixed controls must be clearly visible after installation, in a position that allows the guided part to be directly visible, but far away from moving parts. In the case of a hold-to-run control, this must be installed at a minimum height of 1.5 m from the ground and must not be accessible to the public.
- Where operated with a hold-to-run control, install a STOP button to disconnect the main power supply to the operator, to block movement of the guided part.
- If not already present, apply a permanent tag that describes how to use the manual release mechanism close to it.
- Make sure that the operator has been properly adjusted and that the safety and protection devices and the manual release are working properly.
- Before handing over to the final user, check that the system complies with the harmonised standards and the essential requirements of the Machinery Directive (2006/42/EC).
- Any residual risks must be indicated clearly with proper signage affixed in visible areas, and explained to end users.
- Put the machine's ID plate in a visible place when the installation is complete.
- If the power-supply cable is damaged, it must be immediately replaced by the manufacturer or by an authorised technical assistance centre, or in any case, by qualified staff, to prevent any risk.
- Keep this manual inside the technical folder along with the manuals of all the other devices used for your automation system.
- Make sure to hand over to the end user all the operating manuals of the products that make up the final machinery.
- The product, in its original packaging supplied by the manufacturer, must only be transported in a closed environment (railway carriage, containers, closed vehicles).
- If the product malfunctions, stop using it and contact customer services at <https://www.came.com/global/en/contact-us> or via the telephone number on the website.

 The manufacture date is provided in the production batch printed on the product label. If necessary, contact us at <https://www.came.com/global/en/contact-us>.

 The general conditions of sale are given in the official CAME price lists.

## Main points of danger for people

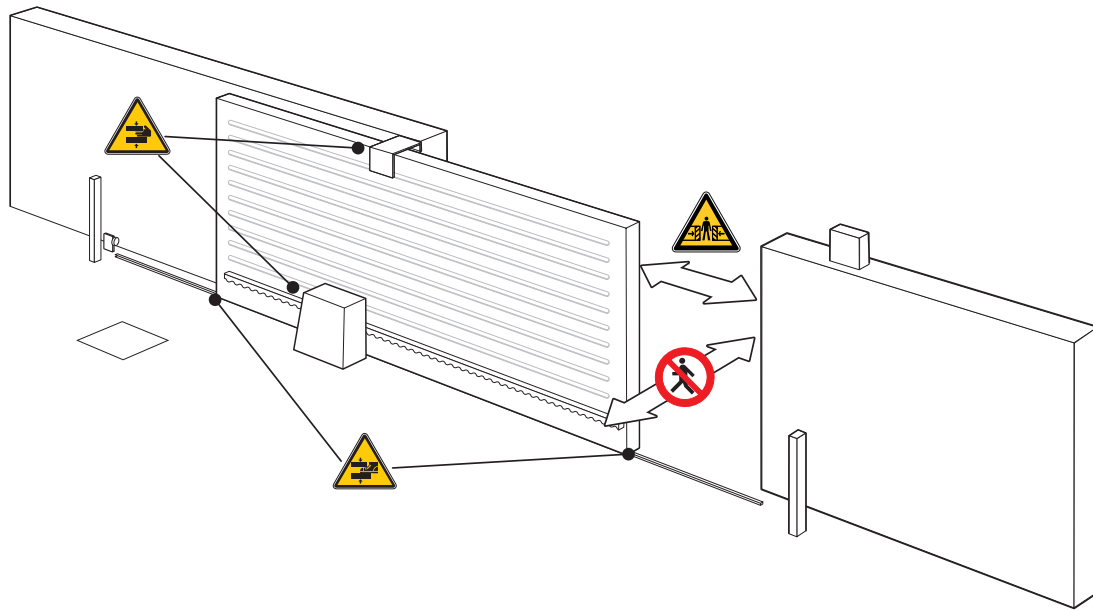

 No transiting while the barrier is moving.

 Danger of crushing.

 Risk of trapping hands.

 Risk of trapping feet.

## DISMANTLING AND DISPOSAL

 CAME S.p.A. employs an Environmental Management System at its premises. This system is certified and compliant with the UNI EN ISO 14001 standard to ensure that the environment is respected and safeguarded. Please continue safeguarding the environment. At CAME we consider it one of the fundamentals of our operating and market strategies. Simply follow these brief disposal guidelines:

### DISPOSING OF THE PACKAGING

The packaging materials (cardboard, plastic, etc.) can be disposed of easily as solid urban waste, separated for recycling. Before dismantling and disposing of the product, please always check the local laws in force.

### DISPOSE OF THE PRODUCT RESPONSIBLY

### DISPOSING OF THE PRODUCT

Our products are made of various materials. Most of these materials (aluminium, plastic, iron and electrical cables) are classified as solid urban waste. They can be separated for recycling and disposed of at authorised waste treatment plants.





Other components (electronic boards, transmitter batteries, etc.) may contain pollutants.

These must be removed and disposed of by an authorised waste disposal and recycling firm.

It is always advisable to check the specific laws that apply in your area.

### DISPOSE OF THE PRODUCT RESPONSIBLY

### Key

-  This symbol shows which parts to read carefully.
-  This symbol shows which parts describe safety issues.
-  This symbol shows what to tell users.
-  The measurements, unless otherwise stated, are in millimetres.

### Description

#### 801MS-0700



BKX12AGM - Operator 230 V with 24 V brushless motor, Adaptive Speed & Torque Technology, featuring a control board with graphic display, CAME Key ready, CXN BUS, B1-B2 output, magnetic limit switch, on-board radio decoding, movement and obstruction detecting device for gates weighing up to 1200 kg that are up to 20 m long. RAL7024 grey cover.

#### 801MS-0720

BKX12RGM - Operator 120 V with 24 V brushless motor, Adaptive Speed & Torque Technology, featuring a control board with graphic display, CAME Key ready, CXN BUS, B1-B2 output, magnetic limit switch, on-board radio decoding, movement and obstruction detecting device for gates weighing up to 1200 kg that are up to 20 m long. RAL7024 grey cover.

### Intended use

Sliding gate solution for residential buildings and apartment blocks.

-  Any installation and/or use other than that specified in this manual is forbidden.
-  After the Green Power module has been connected to the operator, the product complies with Regulation (EU) 2023/826 regarding ecodesign requirements for energy consumption in standby and off mode for household and office equipment.

### Fuse table

MODELS	BKX12AGM	BKX12RGM
Line fuse	3.15A-F	6.3A-F
Control-board fuse	1.6A-T	1.6A-T
Accessories fuse	1.6A-F	1.6A-F
Motor fuse	15A-T	15A-T

## Description of parts

### Operator

- ❶ Cover
- ❷ Green Power module (806XG-0160)\*
- ❸ Battery compartment
- ❹ Housing for SMA or Gateway 4G sensor
- ❺ Gearmotor
- ❻ Anchoring plate
- ❼ Magnetic limit switch
- ❽ Magnetic limit-switch tabs
- ❾ Board protection cover
- ❿ Control board

- ⓫ Housing for two emergency batteries
- 📖 Only use emergency batteries 5Ah (88018-0029).
- ⓬ Housing for thermostat
- ⓭ Housing for thermostat cartridge
- ⓮ Release lever
- ⓯ Transformer
- ⓰ Housing for the RGSM001/S or RSLV001 module
- ⓱ Control board holder

(\*) Only for the 801MS-0700 model.

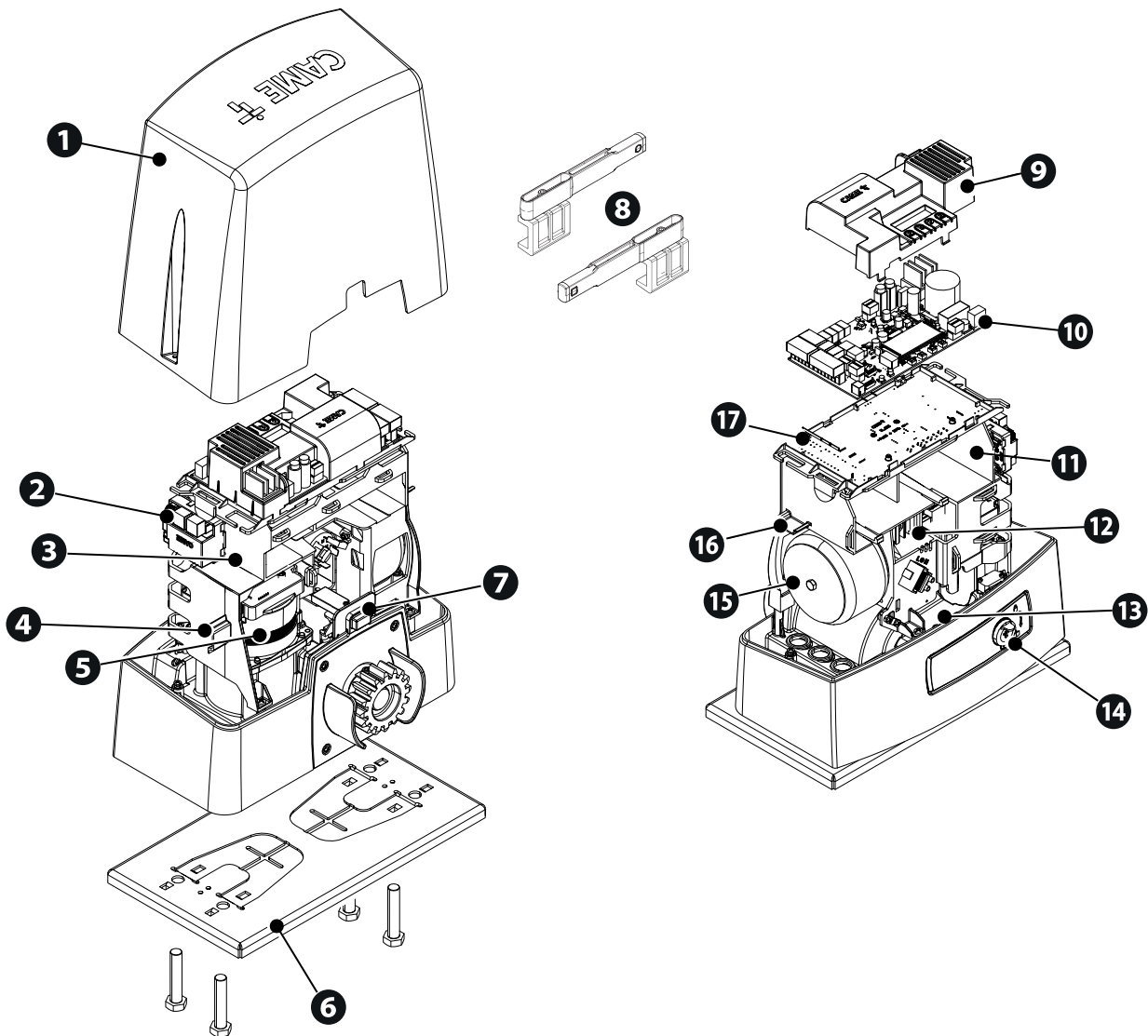

## Control board ZBB3

The functions on the input and output contacts, the time settings and user management are set and viewed on the display.

All connections are protected by quick fuses.

For the system to work properly, before fitting any plug-in card, DISCONNECT THE MAIN POWER SUPPLY and remove any batteries.

Before working on the control panel, disconnect the mains power supply and remove the batteries, if any.

- |   |   |
|---|---|
| <ul style="list-style-type: none"> <li>❶ Terminal board for connecting control devices</li> <li>❷ Terminal board for connecting the safety devices</li> <li>❸ Terminal board for connecting the signalling devices</li> <li>❹ Terminal board for B1-B2 output</li> <li>❺ Connector for the RIOCN8WS module</li> <li>❻ Terminal board for CXN BUS accessories</li> <li>❼ Memory Roll card connector</li> <li>❽ Terminal board for connecting the limit switches</li> <li>❾ Accessories fuse</li> <li>❿ Control board fuse</li> <li>⓫ Terminal board for power supply to the control board</li> <li>⓬ Motor fuse</li> <li>⓭ Line fuse</li> <li>⓮ Power supply terminal board</li> </ul> | <ul style="list-style-type: none"> <li>⓯ Terminal board for connecting the gearmotor</li> <li>⓰ Terminal board for connecting the LBNX battery charger and Green Power module*</li> <li>⓱ Display</li> <li>⓲ Programming buttons</li> <li>⓳ Connector for CAME KEY</li> <li>⓴ RSE_1 connector for RSE card</li> <li>⓵ RSE_2 connector for RSE card</li> <li>⓶ Terminal block associated with the RSE_1 connector for paired or CRP connection</li> <li>⓷ Terminal board associated with the RSE_2 connector for CRP or MODBUS RTU connection</li> <li>⓸ Connector for plug-in radio frequency card (AF)</li> <li>⓹ Terminal board for connecting the antenna</li> </ul> |
|---|---|

(\*) Only for the 801MS-0700 model.

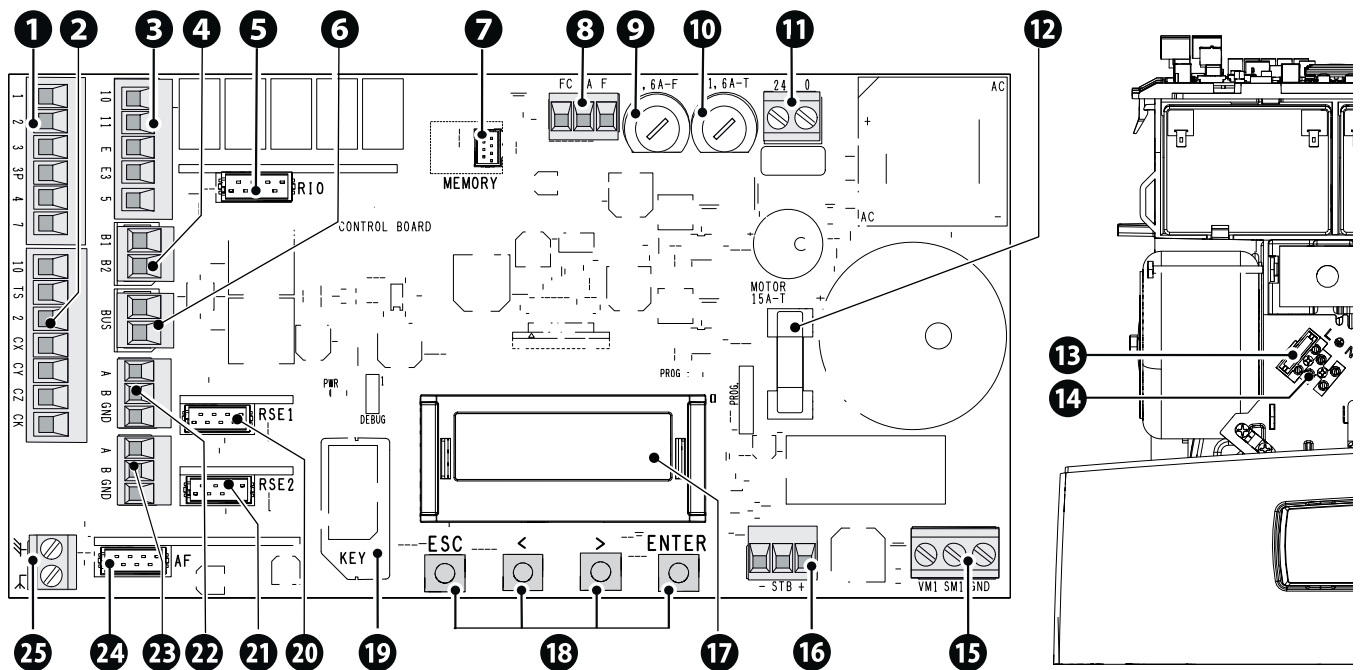

## Remove the cover

 Remove the card cover before inserting the cards into the connectors.

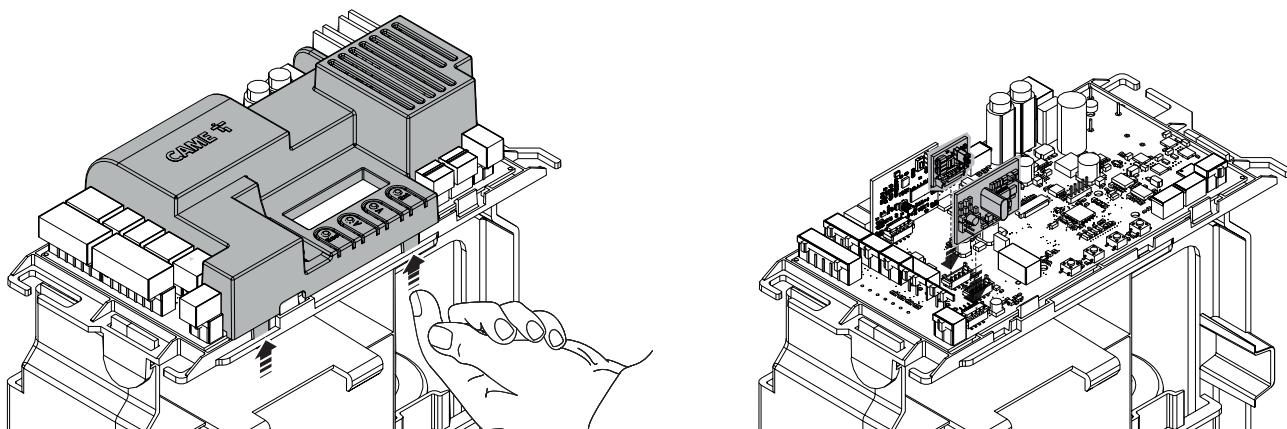

## Size

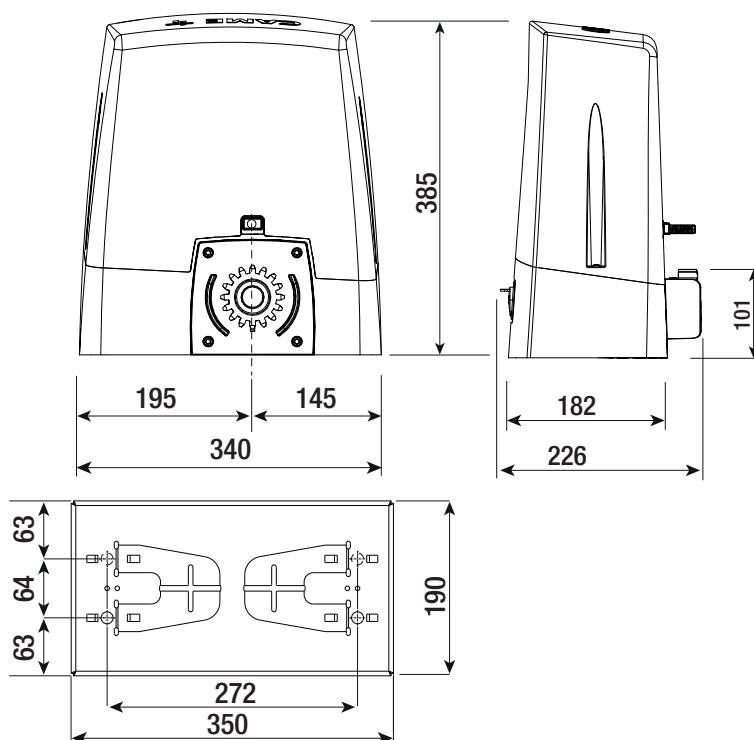

## Usage limitations

MODELS	BKX12AGM	BKX12RGM
Maximum gate-leaf length (m)	20	20
Maximum gate-leaf weight (kg)	1200	1200

## Technical data

MODELS	BKX12AGM	BKX12RGM
Power supply (V - 50/60 Hz)	230 AC	120 AC
Motor power supply (V)		24 DC
Standby consumption (W)	0,8	5
Power (W)		360
Operating temperature (°C)		-20 ÷ +55
Storage temperature (°C) *		-20 ÷ +70
Thrust (N)		800
Maximum operating speed (m/min)		20
Sound pressure level (dB A)		≤70
Control board		ZBB3
Pinion module		4
Protection rating (IP)		54
Insulation class		I
Type of grease		Synthetic (-50°C to 160°C)
Quantity of grease (g)		90
NLGI grade		2
Colour		RAL 7024
Weight (kg)		17
Average life (years)**		15

(\*) Before installing the product, keep it at room temperature where it has previously been stored or transported at a very high or very low temperature.

(\*\*) The average product life specified should be understood purely as an indicative estimate. It applies to normal usage conditions and where the product has been installed and maintained in compliance with the instructions provided in the CAME technical manual. The average product life is also affected, including significantly, by other variables such as, but not limited to, climatic and environmental conditions (where present, see the MCBF table). The average product life should not be confused with the product warranty.

## Operating cycles

 The cycles calculation applies to standard length gates that are professionally installed, with no mechanical issues and/or accidental friction points, measured at ambient temperature at 20°C and at 55°C, as stated in EN standard 60335-2-103.

MODELS	BKX12AGM - BKX12RGM	
Standard leaf length (m)	4	10
Cycles/hour at 20°C (no.)	CONTINUOUS OPERATION	38
Cycles/hour at 55°C (no.)	76	32

## Cable types and minimum thicknesses

Cable length (m)	up to 20	from 20 to 30
Power supply 230 V AC	3G x 1.5 mm <sup>2</sup>	3G x 2.5 mm <sup>2</sup>
24 V AC/DC flashing beacon	2 x 1 mm <sup>2</sup>	2 x 1 mm <sup>2</sup>
TX Photocells	2 x 0.5 mm <sup>2</sup>	2 x 0.5 mm <sup>2</sup>
RX photocells	4 x 0.5 mm <sup>2</sup>	4 x 0.5 mm <sup>2</sup>
Command and control devices	*no. x 0.5 mm <sup>2</sup>	*no. x 0.5 mm <sup>2</sup>

\* no. = see product assembly instructions - Warning: the cable cross-section is indicative and varies according to the motor power and cable length.

📖 When operating at 230 V and outdoors, use H05RN-F cables compliant with 60245 IEC 57 (IEC); when operating indoors, use H05VV-F cables compliant with 60227 IEC 53 (IEC). For power supplies up to 48 V, you can use FROR 20-22 II cables compliant with EN 50267-2-1 (CEI).

📖 To connect the antenna, use RG58 cable (up to 5 m).

📖 For paired connection and CRP, use UTP CAT5 cable (up to 1,000 m).

📖 If the cable lengths differ from those specified in the table, define the cable cross-sections according to the actual power draw of the connected devices and in line with regulation CEI EN 60204-1.

📖 For multiple, sequential loads along the same line, recalculate the values in the table according to the actual power draw and distances. For information on connecting products not covered in this manual, please see the documentation accompanying the products themselves.

## INSTALLATION

The following illustrations are examples only. The space available for fitting the operator and accessories varies depending on the area where it is installed. It is up to the installer to find the most suitable solution.

The drawings show an operator fitted on the left.

### Preliminary operations

Dig a hole for the foundation frame.

Set up the corrugated tubes needed for the wiring coming out of the junction pit.

Use  $\varnothing 40$  mm corrugated tubes to connect the gearmotor to the accessories.

Prepare a  $\varnothing 20$  mm tube to run the release cord through. **A**

The number of tubes depends on the type of system and the accessories that are going to be fitted.

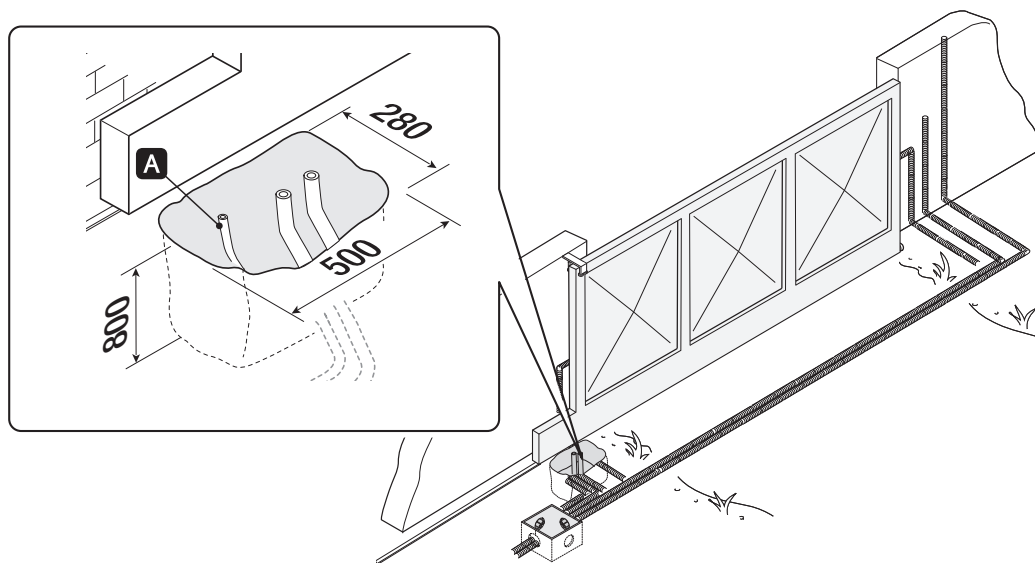

### Laying the anchoring plate

Set up a foundation frame that is larger than the anchoring plate.

Insert the foundation frame into the dug hole.

The foundation frame must protrude by 50 mm, above ground level.

Fit an iron cage in the foundation frame to reinforce the concrete.

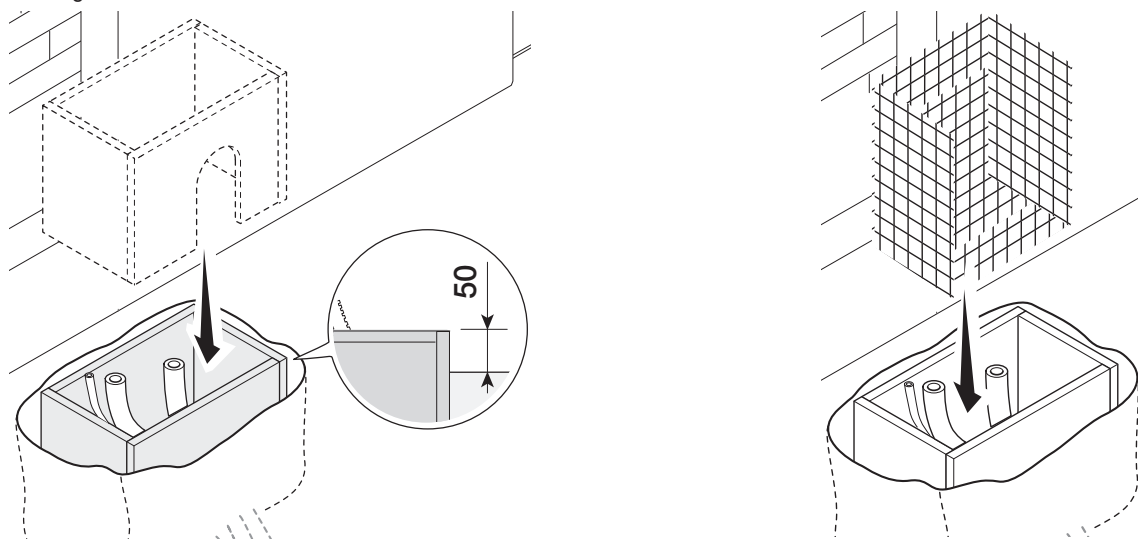

Insert the screws supplied in the anchoring plate.  
 Lock the screws in place with the nuts supplied.  
 Remove the pre-shaped clamps using a screwdriver.  
 Fit the anchoring plate in the iron cage.

The tubes must pass through the existing holes.

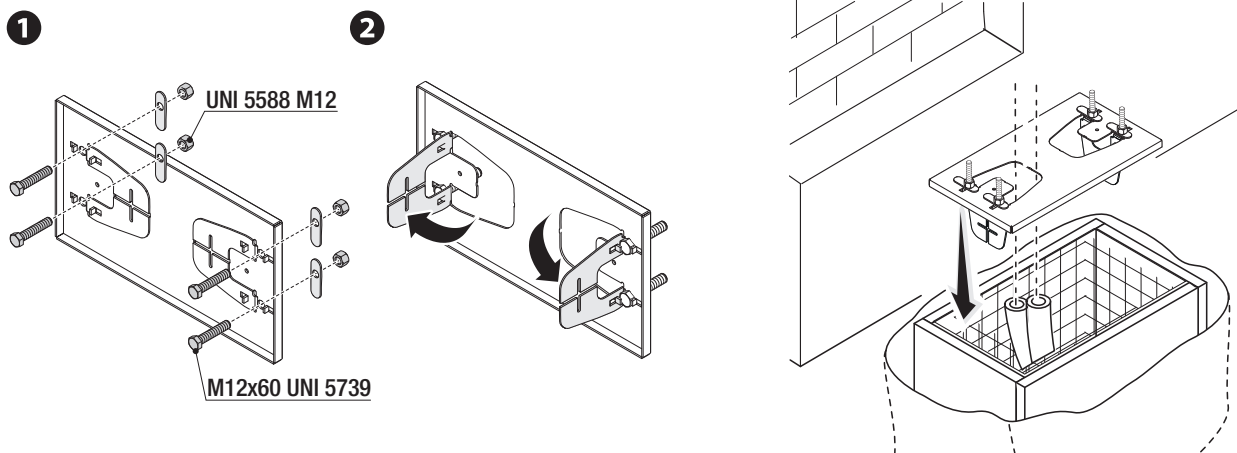

Position the anchoring plate, taking note of the measurements shown in the drawing.

If the gate does not have a rack, proceed with the installation. See the section FASTENING THE RACK.

See the section "FASTENING THE RACK".

Cast cement into the foundation frame.

The plate must be perfectly level and the screw threads completely above surface.

Wait at least 24 hours for the cement to dry.

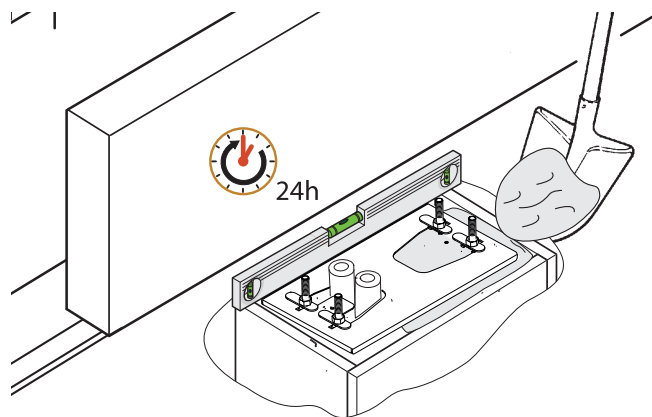
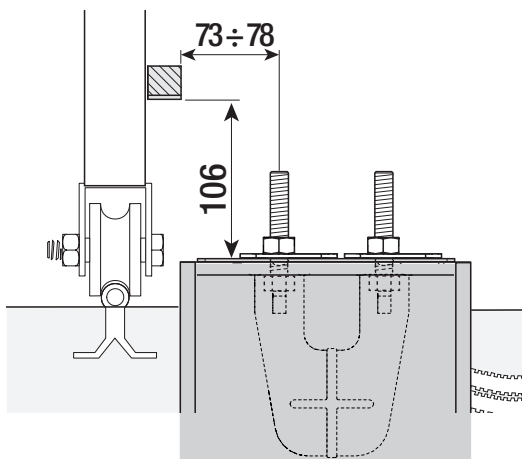

Remove the foundation frame.  
Fill the hole with soil around the concrete block.

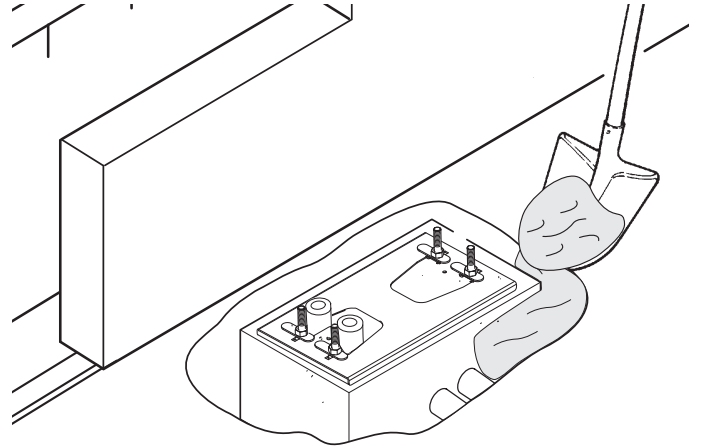
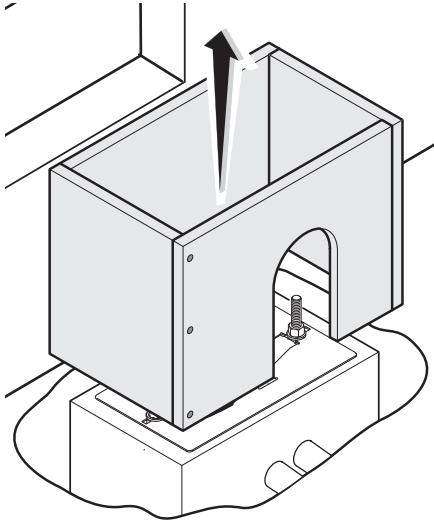

Remove the nuts from the screws.  
Insert the electrical cables into the tubes until they protrude by about 600 mm.

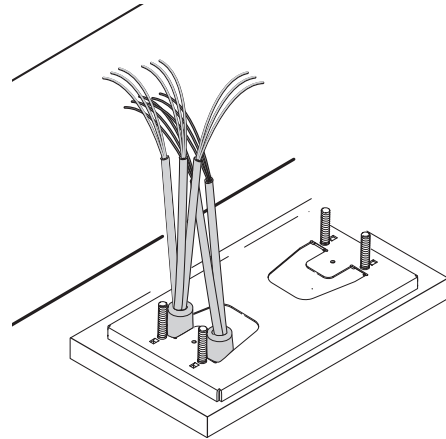
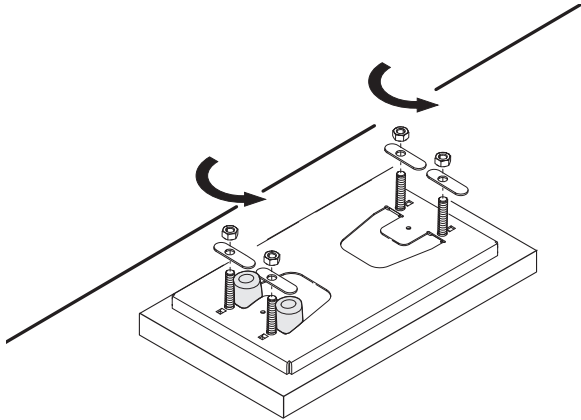

## Setting up the operator

Remove the operator cover.  
Place the operator on top of the anchoring plate.

 The electrical cables must pass under the operator foundation frame

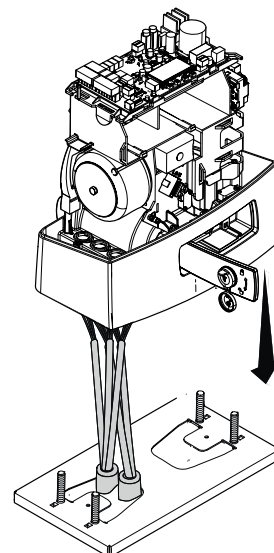
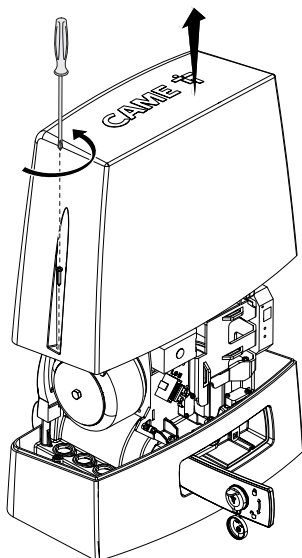

Make a hole in the cable gland.

Thread the cables through the cable gland.

Lift the operator by 5-10 mm from the plate by adjusting the threaded feet, to allow for any adjustments that may need to be made between the rack and pinion.

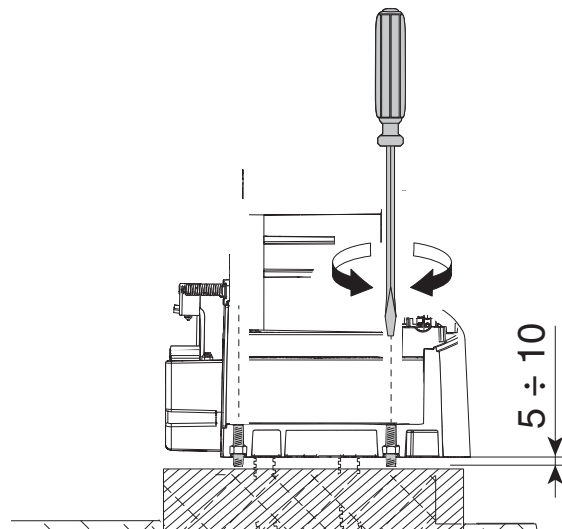
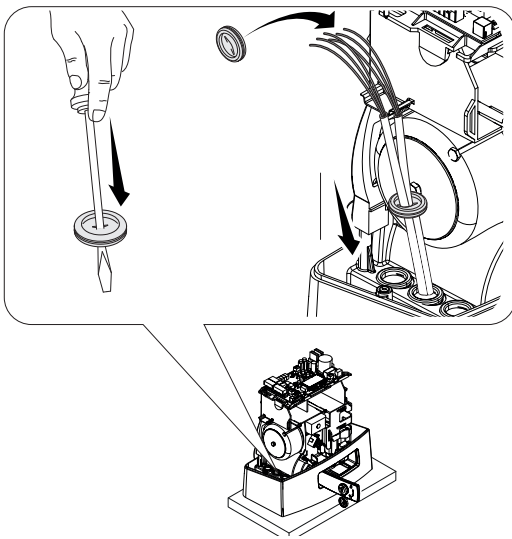

## Fastening the rack

- 1 Release the operator.
- 2 Rest the rack on the pinion.
- 3 Weld or fasten the rack to the gate along its entire length.

 To assemble the rack modules, use an extra piece and rest it under the join, then fasten it in place using two clamps.

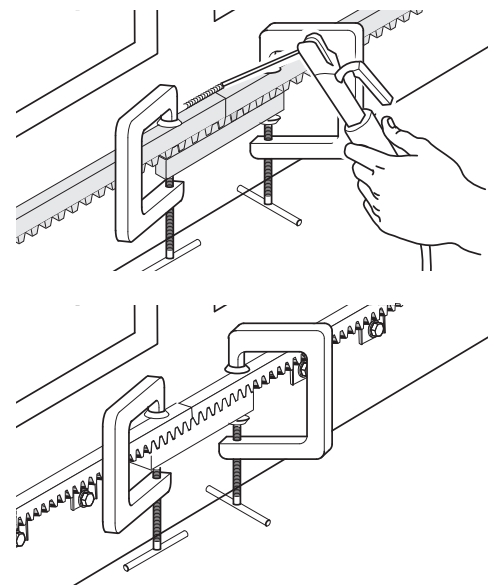
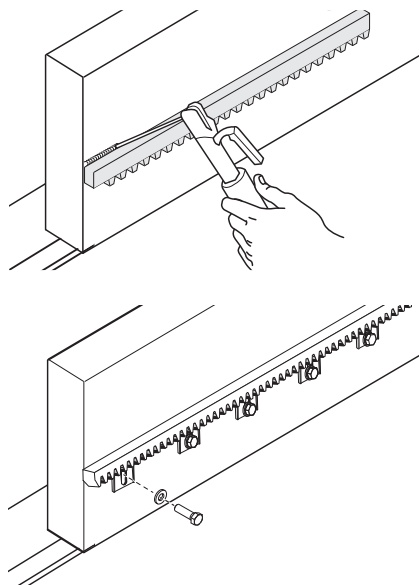
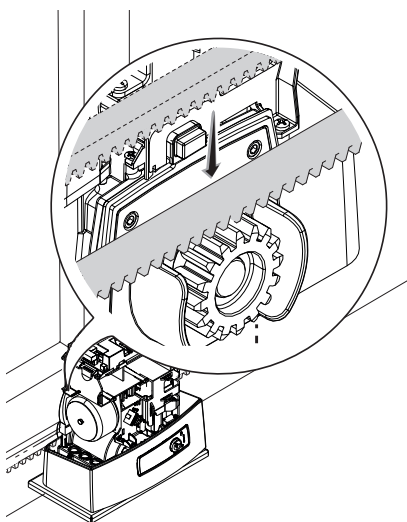

## Adjusting the pinion-rack coupling

Open and close the gate manually.

Adjust the pinion-rack coupling distance using the threaded feet (vertical adjustment) and the holes (horizontal adjustment).

 The weight of the gate must not bear down upon the operator.

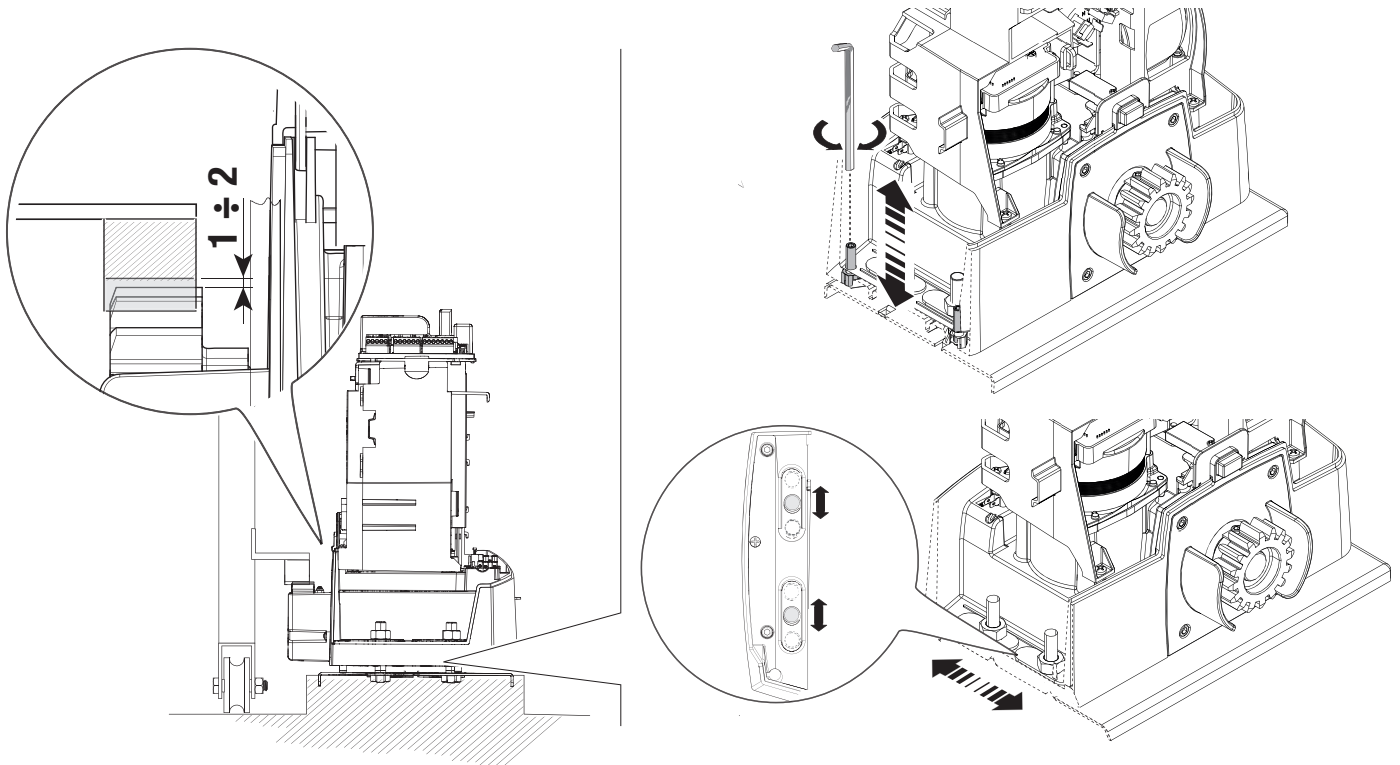

## Fastening the operator in place

 Only fasten the operator after adjusting the pinion-rack coupling.

Fasten the operator to the anchoring plate using stoppers and nuts.

 The operator can also be fixed with 70 mm nuts (code 88001-0273).

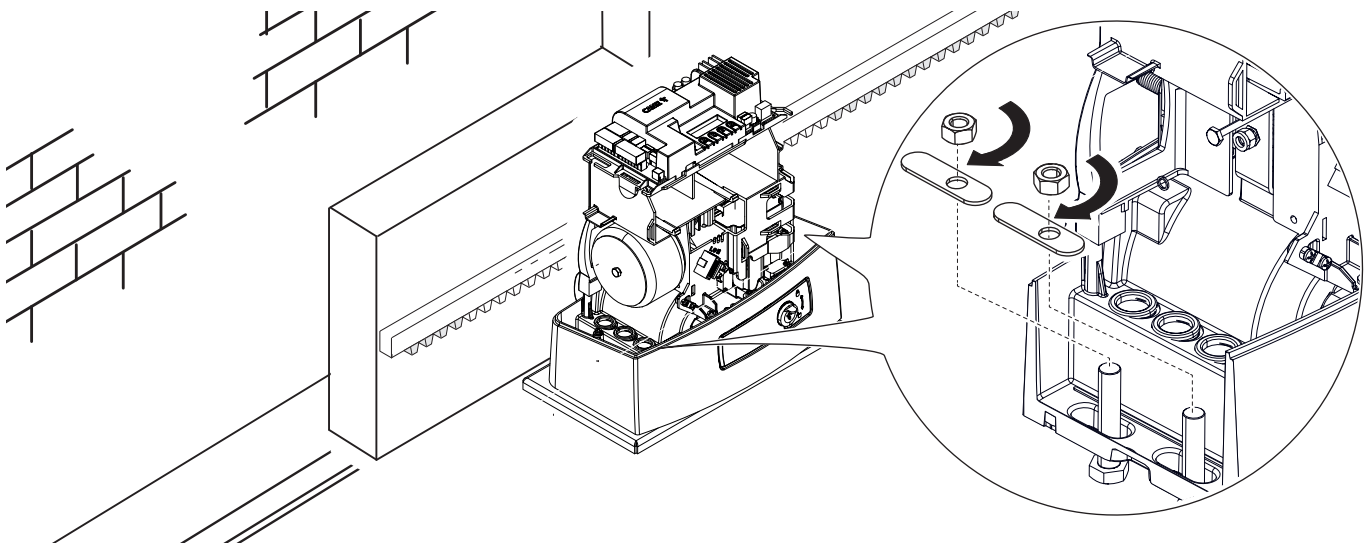

## Establishing the travel end points with magnetic limit switches

- A** Magnetic limit-switch tab during closing
- B** Magnetic limit-switch tab during opening

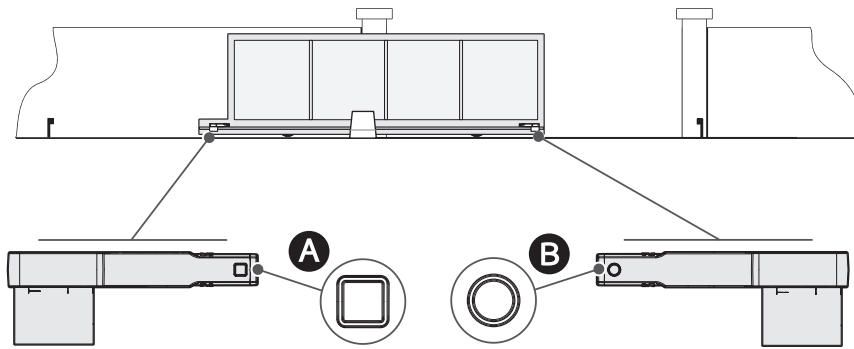

- 1** Open the gate.
- 2** Insert the magnetic opening limit-switch tab on the rack.
- 3** The tab magnet must be between 10 and 30 mm from the magnetic sensor.

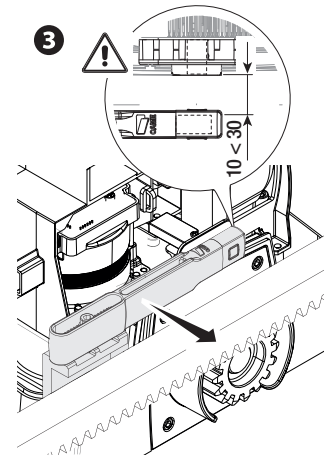
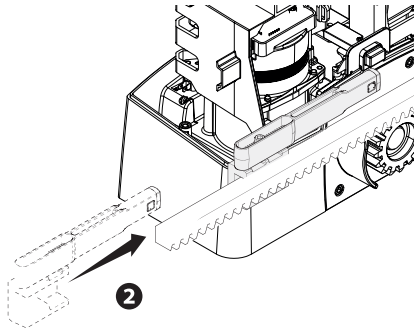
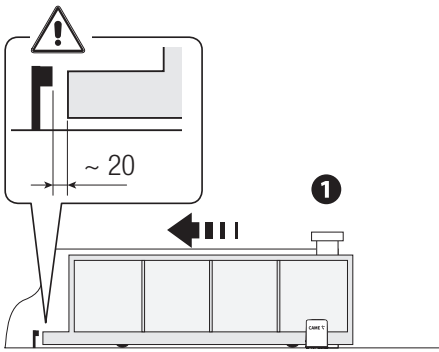

- 4** Fasten the support to the rack using the grub screws supplied.
- 5** The limit-switch tab magnet must be perpendicular to the magnetic sensor.
- 6** Fasten the limit-switch tab using the screw (supplied).

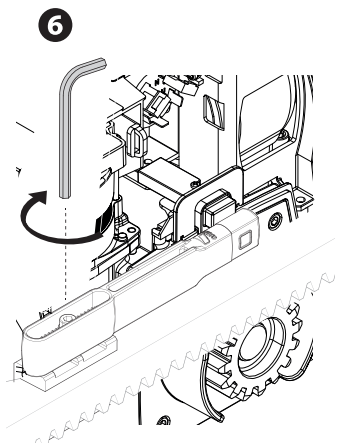
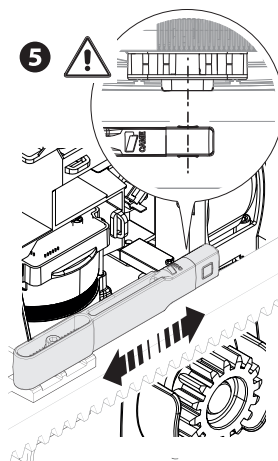
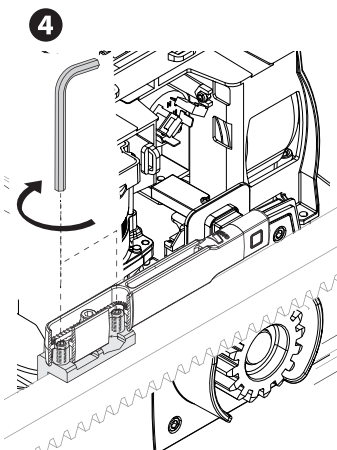

- 1 Close the gate.
- 2 Insert the magnetic closing limit-switch tab on the rack.
- 3  The tab magnet must be between 10 and 30 mm from the magnetic sensor.

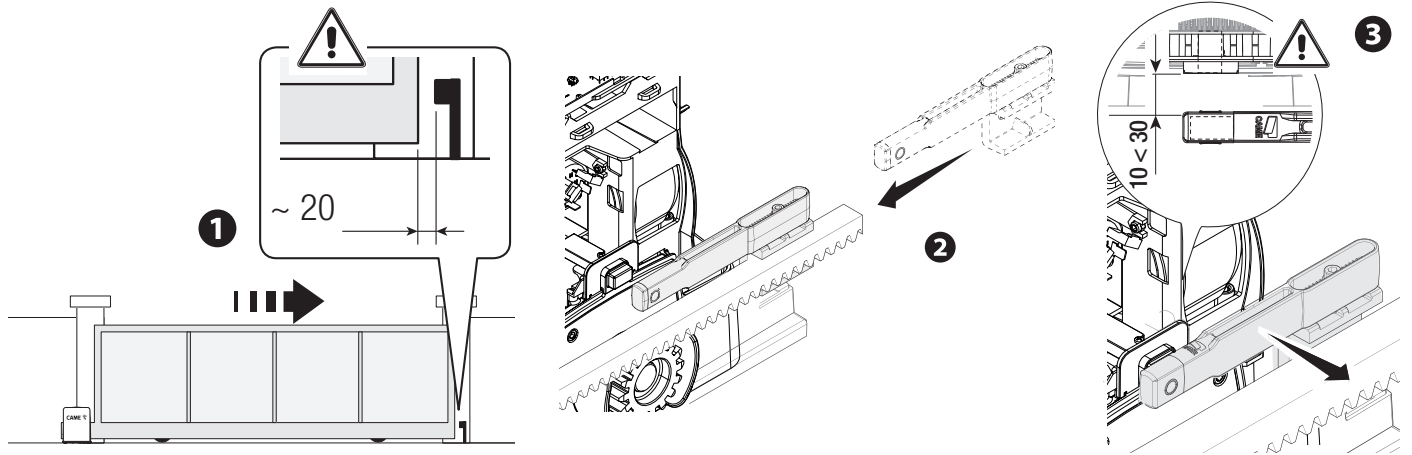

- 4 Fasten the support to the rack using the grub screws supplied.
- 5  The limit-switch tab magnet must be perpendicular to the magnetic sensor.
- 6 Fasten the limit-switch tab using the screw (supplied).

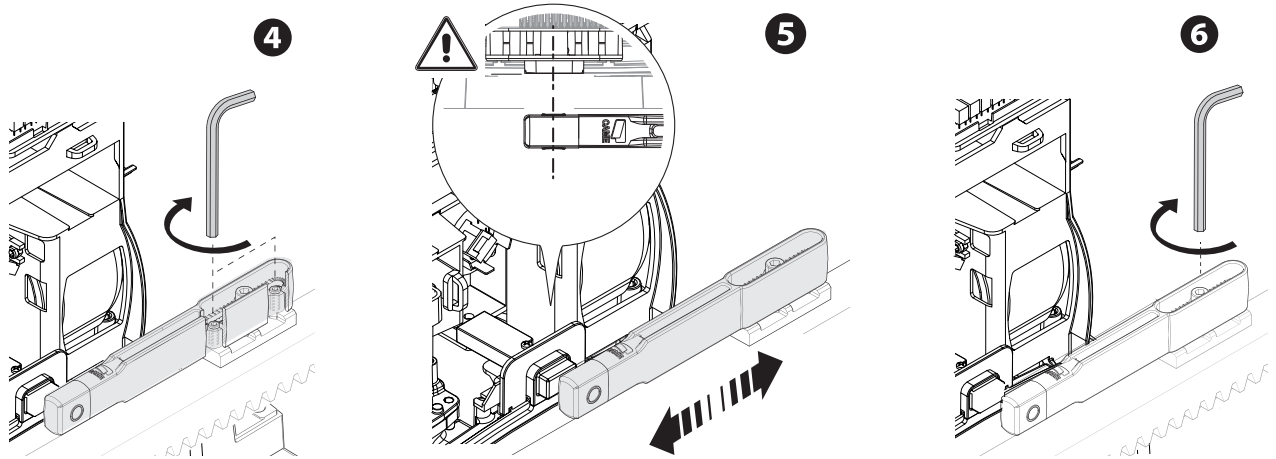

### Passing the electrical cables

📖 Connect all wires and cables in compliance with the law.

The electrical cables must not touch any parts that may overheat during use (such as the motor and transformer).

📖 Use membrane cable glands to connect the devices to the control panel. One cable gland must be intended exclusively for the power supply cable.

⚠ Thread the cables through the holes in the control board holder (A). The cables need to sit perfectly flush to the side of the operator as shown below to ensure the cover closes. Use cable ties or insulating tape if necessary.

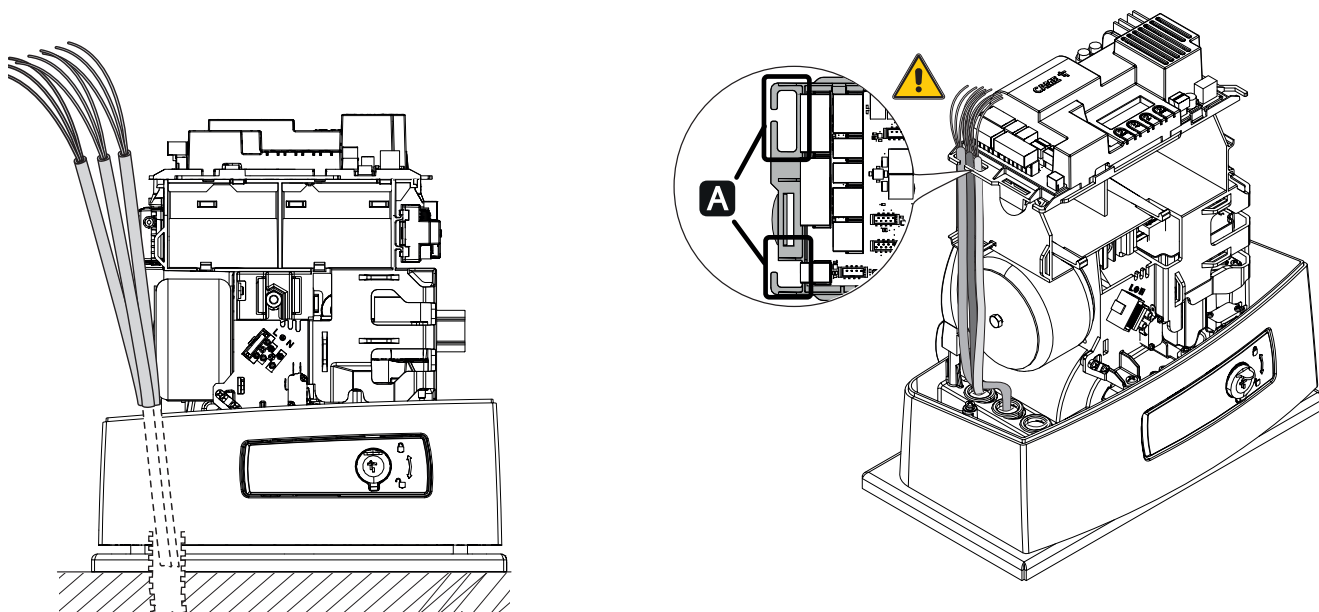

## Connecting to the electrical network

Make sure the mains power supply is disconnected during all installation procedures.

⚠ Before working on the control panel, disconnect the mains power supply and remove the batteries, if any.

### Power supply 230/120 V AC - 50/60 Hz

**F** - Line fuse

**L** - Phase

**N** - Neutral

⊕ - Earth

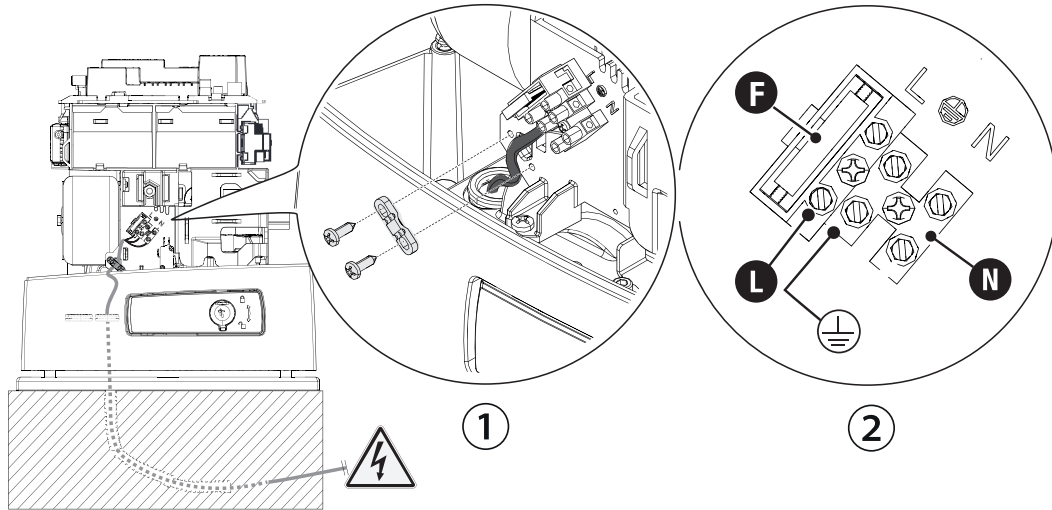

## Connecting accessories

### Power supply output for accessories 24 V

📖 The total power of the outputs listed below must not exceed the maximum output power [Accessories]

Device	Output	Power supply (V)	Maximum power (W)
Accessories	10 - 11	24 AC	40
Flashing beacon	10 - E	24 AC	20
Additional light	10 - E3	24 AC	20
Passage-open warning light	10 - 5	24 AC	3

The outputs deliver 24 V DC when the batteries start operating, if they are installed.

### CXN BUS connection

⚠ The output is set for CAME CXN BUS accessories only.

Device	Output	Power supply (V)	Maximum power (W)
BUS CXN	BUS	15 DC	15

### Auxiliary connection output

📖 See the [Output B1-B2] function.

Device	Output	Rated current (A)	Rated voltage (V)
Auxiliary contact	B1 - B2	1	24 AC/DC

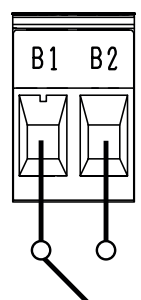

## Connecting accessories with BUS CXN system

The CXN CAME system is a two-wire non-polarised communication BUS which allows you to connect up all compatible CAME devices. Connection to the BUS can be in a chain, star or mixed formation. Once the system has been wired, and after having set the address on each device, the function of each accessory can be configured on the control panel. This method allows you to configure the set-up immediately without having to work directly on the accessories and system wiring later. The CXN BUS can support control devices, interfaces, photocells, safety devices, beacons and gateways at the same time.

### Cabling

- ❶ Chain connection
- ❷ Star connection
- ❸ Mixed connection

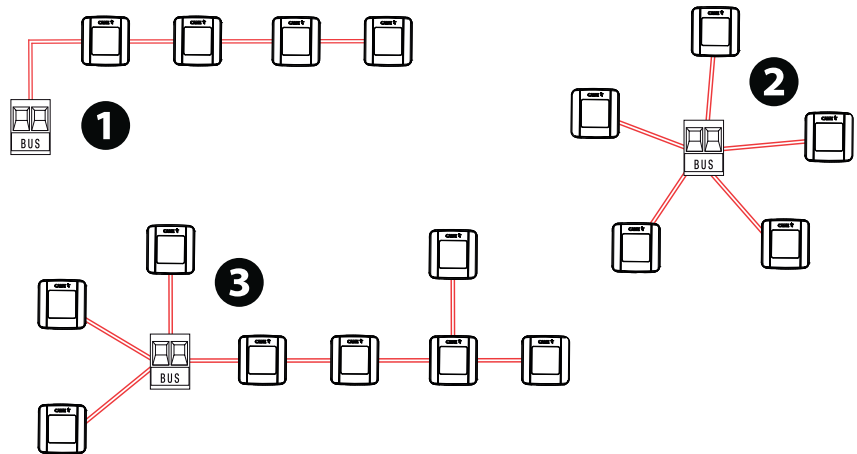

### Cable types and minimum thicknesses

Branch length	0 to 15 m	15 to 50 m
KRX BUS flashing beacon (max. 1 per branch)	FROR 2 x 0.5 mm <sup>2</sup>	FROR 2 x 1 mm <sup>2</sup>
Branch load below 20 CXN	FROR 2 x 0.5 mm <sup>2</sup>	FROR 2 x 0.5 mm <sup>2</sup>
Branch load above 20 CXN	FROR 2 x 0.5 mm <sup>2</sup>	FROR 2 x 1 mm <sup>2</sup>

📖 Do not use a shielded cable.

⚠️ The maximum length of a single branch is 50 metres. The sum of all branches must not exceed 150 metres.

### Maximum number of devices that can be connected, by type

Type of device	Maximum number of devices per type
Selectors	8
Photocell pairs	8
Interfaces	2
Flashing beacons	2

### BUS CXN device consumption



[LINK](#)

📖 BUS CXN device consumption is calculated in CXN units.

Scan the QR code to access an interactive table showing consumption data, and calculate the maximum number of BUS devices you can connect to the control panel.

## Command and control devices

1  
2

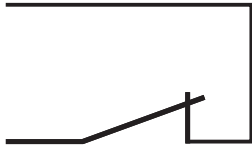

### STOP button (NC contact)

This stops the operator and excludes automatic closing. Use a control device to resume movement.

📖 When the contact is being used, it must be activated during programming.

📖 See function [Total stop].

2  
3



### Control device (NO contact)

Open command

📖 When the [Hold-to-run] function is active, a control device must be set to OPEN.

2  
3P



### Control device (NO contact)

Partial Opening command

📖 See [Adjusting partial opening] function.

2  
4



### Control device (NO contact)

Close command

📖 When the [Hold-to-run] function is active, a control device must be set to CLOSE.

2  
7



### Control device (NO contact)

Step-by-step command

Sequential command



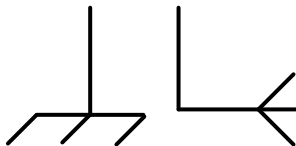

📖 See control [Function 2-7].

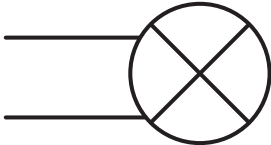

### Antenna with RG58 cable

Use this terminal to connect the antenna.

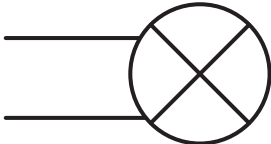
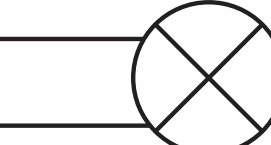
## Signalling devices

- 10 E3**  **Additional light**  
It increases the light in the manoeuvring area.  
 See [Additional light] function.
- 10 E**  **Flashing beacon**  
It flashes when the operator opens and closes.
- 10 5**  **Operator status warning light (Passage-open warning light)**  
 See function [Passage-open warning light].

## Photocells and sensitive edges

Connect the devices to inputs CX, CY CZ and/or CK.

During programming, configure the type of action that must be performed by the device connected to the input.

 If contacts CX, CY, CZ and CK are used, they must be configured during programming.

 For systems with multiple pairs of photocells, please see the manual for the relevant accessory.

### Standard connection

### Connection with safety test

 See [Safety devices test] function.

### DIR photocells

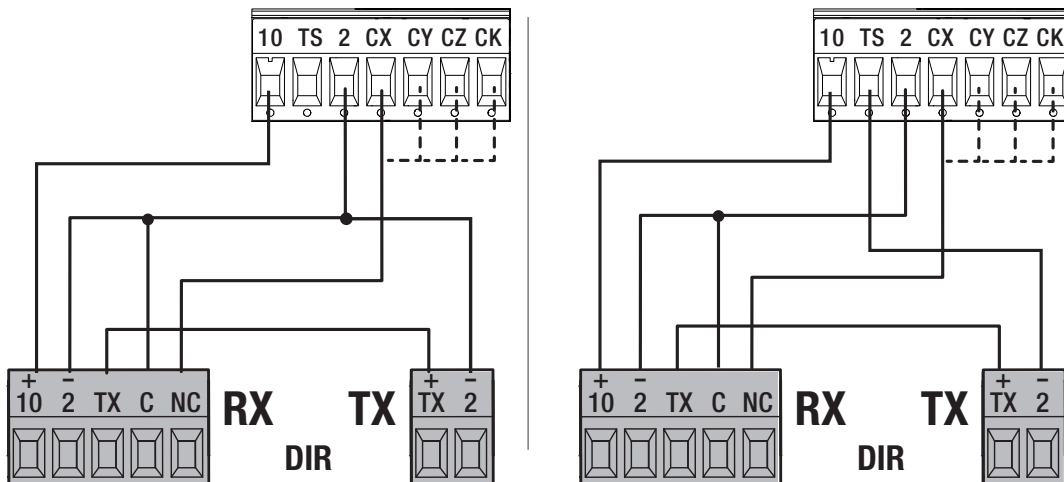

Standard connection

Connection with safety test

See [Safety devices test] function.

DXR / DLX photocells

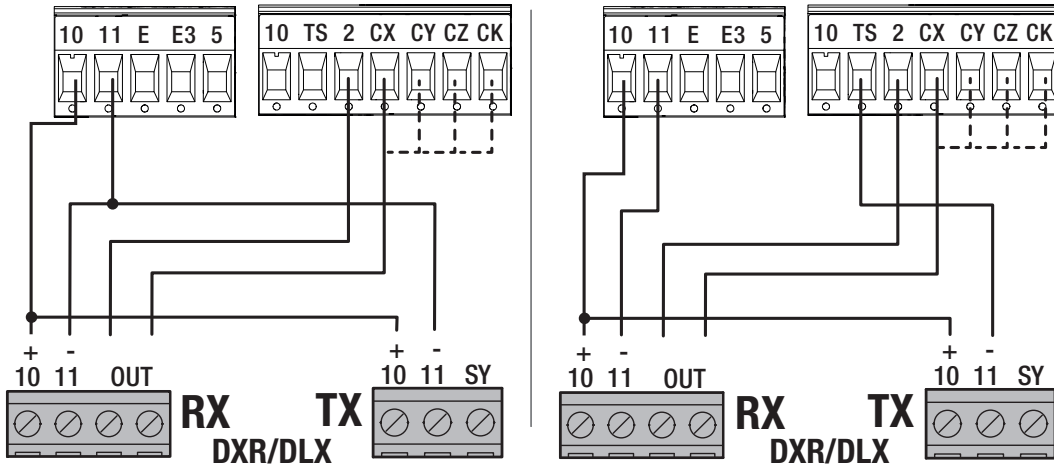

DFWN sensitive edge

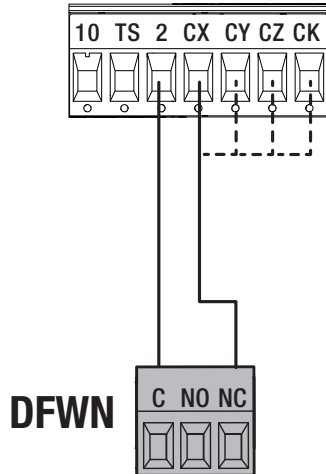

Programming button functions

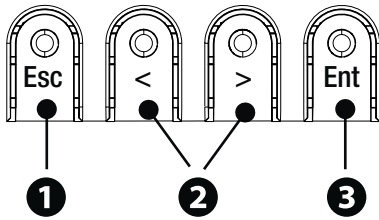

❶ ESC button

The ESC button is used to perform the operations described below.  
 Exit the menu  
 Delete the changes  
 Go back to the previous screen  
 Stop the operator

❷ < > buttons

The < > buttons are used to perform the operations described below.  
 Navigate the menu  
 Increase or decrease values  
 Open or close the operator

❸ ENTER button

The ENTER button is used to perform the operations described below.  
 Access menus  
 Confirm a choice

Getting started

- 📖 Once the electrical connections have been made, proceed with commissioning. Only skilled and qualified staff may perform this operation.  
 Make sure that there are no obstacles in the way.  
 Power up the device and follow the instructions on the display.  
 Start programming following the wizard.
- 📖 If this is not the first time the board is being switched on, go to the menu Configuration > Wizard. Follow the indications shown on the display.
- ⚠ Complete programming and check the warning, safety and protection devices, and the manual release, are working properly.
- 📖 After powering up the system, the first manoeuvre is always to open the gate; Wait for the manoeuvre to be completed.
- 📖 Press the **ESC** button or **STOP** button immediately in the event of any faults, malfunctions, strange noises or vibrations, or unexpected behaviour in the system.

FUNCTIONS MENU

⚠ **When using a CAME KEY device, always update the board firmware to the latest version.**

📖 Some functions may not be available with firmware versions prior to the latest one or without some accessory devices.

Configuration

Motor settings

Path: CONFIGURATION > MOTOR SETTINGS > Opening direction

<b>Opening direction</b>	To the left (Default) To the right	The function is used to set the gate opening direction.
--------------------------	---------------------------------------	---

*Path:* CONFIGURATION > MOTOR SETTINGS > **Motor test**

<b>Motor test</b>	<p>The &gt; button moves the gate to the right</p> <p>The &lt; button moves the gate to the left</p>	<p>The function is used to check the gate opens in the right direction.</p> <p> <b>The gate will move at reduced speed.</b></p>
-------------------	--	---

*Path:* CONFIGURATION > MOTOR SETTINGS > **Travel calibration**

<b>Travel calibration</b>	The function is used to start travel self-learning.	
---------------------------	---	--

*Path:* CONFIGURATION > MOTOR SETTINGS > **Motor type**

<b>Motor type</b>	BKX12	The function is used to set the type of gearmotor installed.
-------------------	-------	--

*Path:* CONFIGURATION > MOTOR SETTINGS > **Motor power**

<b>Motor power</b>	<p>30% to 130% (Default 100%)</p> <p> <b>At 100%, the maximum thrust is the one pre-defined for the type of motor set. Increasing or decreasing the percentage increases or decreases the maximum thrust.</b></p>	<p>The function allows you to increase or decrease the maximum thrust of the motor during a manoeuvre.</p> <p> <b>Decreasing the thrust increases the obstacle-detection sensitivity.</b></p>
--------------------	---	---

**Gate travel settings**

*Path:* CONFIGURATION > GATE TRAVEL SETTINGS > **Opening speed**

<b>Opening speed</b>	25% to 100% (Default 70%)	The function is used to set the opening speed. The percentage is calculated based on the maximum travel speed.
----------------------	---------------------------	--

*Path:* CONFIGURATION > GATE TRAVEL SETTINGS > **Closing speed**

<b>Closing speed</b>	25% to 100% (Default 70%)	The function is used to set the closing speed. The percentage is calculated based on the maximum travel speed.
----------------------	---------------------------	--

*Path:* CONFIGURATION > GATE TRAVEL SETTINGS > **Travel AST control**

<b>Travel AST control</b>	<p>Deactivated (Default) = Maximum thrust and low obstruction sensitivity.</p> <p>Minimum</p> <p>Average</p> <p>Maximum = Minimum thrust and high obstruction sensitivity.</p> <p>Customised</p> <p>The personalised values to be used are expressed as a percentage:</p> <ul style="list-style-type: none"> <li>- from 10% (minimum thrust and high obstruction sensitivity)</li> <li>- to 100% (maximum thrust and low obstruction sensitivity)</li> </ul>	<p>The function adjusts the obstacle detection sensitivity during the gate travel in percentage terms.</p>
---------------------------	--	--

*Path:* CONFIGURATION > GATE TRAVEL SETTINGS > **Part. open point**

**Adjusting the partial opening**

10% to 100% (Default 20%)

The function is used to set the partial opening percentage for the gate.

*Path:* CONFIGURATION > GATE TRAVEL SETTINGS > **Op. slowdown space**

**Opening slowdown space**

1% to 50% (Default 1%)

The function is used to set the percentage of the total travel to be used for slowdown during gate opening.

 During travel calibration, the opening slowdown point is automatically set to allow for a slowing space of 60 cm.

*Path:* CONFIGURATION > GATE TRAVEL SETTINGS > **Cl. slowdown space**

**Closing slowdown space**

1% to 50% (Default 1%)

The function is used to set the percentage of the total travel to be used for slowdown during gate closing.

 During travel calibration, the closing slowdown point is automatically set to allow for a slowing space of 60 cm.

*Path:* CONFIGURATION > GATE TRAVEL SETTINGS > **Opening slowdown speed**

**Opening slowdown speed**

5% to 50% (Default 40%)

The function is used to set the opening slowdown speed. The percentage is calculated based on the maximum travel speed.

 The parameter is only used with the [Opening slowdown point] function active.

 If the slowdown speed is incorrectly set to a value higher than the opening speed by mistake, the parameter is corrected.

*Path:* CONFIGURATION > GATE TRAVEL SETTINGS > **Closing slowdown speed**

**Closing slowdown speed**

5% to 50% (Default 40%)

The function is used to set the closing slowdown speed. The percentage is calculated based on the maximum travel speed.





 The parameter is only used with the [Closing slowdown point] function active.

 If the slowdown speed is incorrectly set to a value higher than the closing speed by mistake, the parameter is corrected.

**Path: CONFIGURATION > GATE TRAVEL SETTINGS > Slowdown AST control**

<p><b>Slowdown AST control</b></p>	<p>Deactivated (Default) = Maximum thrust and low obstruction sensitivity.</p> <p>Minimum Average</p> <p>Maximum = Minimum thrust and high obstruction sensitivity.</p> <p>Customised</p> <p>The personalised values to be used are expressed as a percentage:</p> <ul style="list-style-type: none"> <li>- from 10% (minimum thrust and high obstruction sensitivity)</li> <li>- to 100% (maximum thrust and low obstruction sensitivity)</li> </ul>	<p>The function adjusts the obstacle detection sensitivity during slowdown in percentage terms.</p> <p> The parameter is only used if the opening or closing slowdown point is active.</p>
------------------------------------	---	---

**Path: CONFIGURATION > GATE TRAVEL SETTINGS > Impact test**

<p><b>Impact test</b></p>	<p>Activate test mode</p> <p>Deactivate test mode</p> <p>Leaf weight</p> <p>Select the gate weight value closest to the real weight:</p> <p>200 kg to 800 kg (default 800 kg).</p> <p>Preset not available for greater weights.</p> <p>Apply pre-set value</p> <p>Configure the travel parameters according to the set leaf weight.</p> <p> The parameter is only displayed after travel has been calibrated. See the [Travel calibration] function.</p>	<p>The functions activates or deactivates test mode for impact test checks. With the function on, the operator does not signal errors connected to obstacle detection after more than one consecutive impact. The function is also used to pre-set the travel parameters, according to the gate leaf weight and length. The preset values are used for impact test checks.</p> <p> Test mode is deactivated automatically after 1 hour.</p> <p> With the function on, the display shows the  icon.</p>
---------------------------	---	---

**Wired safety devices**

**Path: CONFIGURATION > WIRED SAFETY DEVICES > Total stop**

<p><b>Total stop</b></p>	<p>Deactivated (Default)</p> <p>On</p>	<p>The function is used to manage operator stops and exclusion of all other commands. When the function is activated, the 2-1 input is used as a normally closed contact.</p> <p>By activating a device (normally closed) connected to input 2-1, the operator stops and all commands are excluded, including any automatic closing.</p> <p> Use a control device to resume movement.</p>
--------------------------	--	--

<p><b>CX input</b></p> <p><b>CY input</b></p> <p><b>CZ input</b></p> <p><b>CK input</b></p>	<p>Deactivated (Default)</p> <p>C1 = Reopen while closing (photocells)</p> <p>C2 = Reclose while opening (photocells)</p> <p>C3 = Partial stop Only with [Automatic close] activated.</p> <p>C4 = Obstacle standby (photocells)</p> <p>C7 = Reopen while closing (sensitive edges)</p> <p>C8 = Reclose while opening (sensitive edges)</p> <p>C13 = Reopen while closing, with immediate closure once the obstruction has been removed, even if the gate is not in motion</p> <p>r7 = Reopen while closing (sensitive edges with 8K2 resistor)</p> <p>r8 = Reclose while opening (sensitive edges with 8K2 resistor)</p> <p>r7 (two sensitive edges) = Reopen while closing (pair of sensitive edges with 8K2 resistor)</p> <p>r8 (two sensitive edges) = Reclose while opening (pair of sensitive edges with 8K2 resistor)</p>	<p>The function allows you to configure the CX, CY, CZ and CK inputs.</p>
---	---	---

<p><b>Safety devices test</b></p>	<p>Deactivated (Default)</p> <p>CX _ _ _ _</p> <p>_ CY _ _</p> <p>CX CY _ _</p> <p>_ _ CZ _</p> <p>CX _ CZ _</p> <p>_ CY CZ _</p> <p>CX CY CZ _</p> <p>_ _ _ CK</p> <p>CX _ _ CK</p> <p>_ CY _ CK</p> <p>CX CY _ CK</p> <p>_ _ CZ CK</p> <p>CX _ CZ CK</p> <p>_ CY CZ CK</p> <p>CX CY CZ CK</p>	<p>The function is used to check that the photocells connected to the selected inputs are operating correctly, after each opening and closing command.</p> <p> Run the test by connecting the photocells to the TS terminal [see paragraph Photocells and sensitive edges].</p>
-----------------------------------	---	--

## RIO safety devices

*Path:* CONFIGURATION > RIO SAFETY DEVICES > **RIO ED T1 / RIO ED T2**

<b>RIO ED T1</b>	Deactivated (Default) P0 = It stops the gate and excludes automatic closing. Use a control device to resume movement.	The function is used to configure a wireless safety device.  The function only appears if the RIO CONN interface board is present.
<b>RIO ED T2</b>	P7 = Reopen while closing. P8 = Reclose while opening.	

*Path:* CONFIGURATION > RIO SAFETY DEVICES > **RIO PH T1 / RIO PH T2**

<b>RIO PH T1</b>	Deactivated (Default) P1 = Reopen while closing. P2 = Reclose while opening. P3 = Partial stop. Only with [Automatic close] activated.	The function is used to configure a wireless safety device.  The function only appears if the RIO CONN interface board is present.
<b>RIO PH T2</b>	P4 = Obstacle standby. P13 = Reopening during closure with immediate stop once the obstacle has been removed, even with the gate not in motion.	

## BUS Devices

### BUS (b1-b8) photocell functions

*Path:* CONFIGURATION > BUS DEVICES > **BUS (1 - 8) photocell \***

<b>BUS Photocell 1</b>	Deactivated (Default) C1 = Reopen while closing (photocells)	The function is used to configure the BUS photocell input.  The function only appears if there is a BUS photocell connected.
<b>Photocell BUS 2</b>	C2 = Reclose while opening (photocells)	
<b>Photocell BUS 3</b>	C3 = Partial stop Only with [Automatic close] activated.	
<b>Photocell BUS 4</b>	C4 = Obstacle standby (photocells)	
<b>Photocell BUS 5</b>	C13 = Reopen while closing, with immediate closure once the obstruction has been removed, even if the gate is not in motion	
<b>Photocell BUS 6</b>		
<b>Photocell BUS 7</b>		
<b>Photocell BUS 8</b>	Open Close	

(\*) As set on the device DIP switch.



## BUS (b21-b28) key selector switch functions

Path: CONFIGURATION > BUS DEVICES > <b>BUS (1 - 8) key selector switch *</b>		
<b>BUS 1 key selector</b>	Open	Associate a function with the BUS key selector input. Different functions can be set according to the key turning direction. - Key to the right - Key to the left  The function only appears if there is a BUS key selector connected.
<b>BUS 2 key selector</b>	Close	
<b>BUS 3 key selector</b>	Partial opening	
<b>BUS 4 key selector</b>	Stop	
<b>BUS 5 key selector</b>	B1-B2 output	
<b>BUS 6 key selector</b>	BUS 1 module relay - Activate output 2 (relay output) on BUS 1 I/O module	
<b>BUS 7 key selector</b>	BUS 2 module relay - Activate output 2 (relay output) on BUS 2 I/O module	
<b>BUS 8 key selector switch</b>	Step-by-step - The first command is to open and the second to close. Sequential - The first command is to open, the second to STOP, the third to close and the fourth to STOP.	

(\*) As set on the device DIP switch.



## I/O BUS 1 (b11) module / I/O BUS 2 (b12) module functions\*

(\*) As set on the device DIP switch.

Path: CONFIGURATION > BUS DEVICES > I/O MODULE BUS 1 > <b>Input I1 / Input I2</b>		
Path: CONFIGURATION > BUS DEVICES > I/O MODULE BUS 2 > <b>Input I1 / Input I2</b>		
<b>input I1</b> <b>input I2</b>	Deactivated (Default) Stop = Stop the gate and exclude automatic closing. Use a control device to resume movement.  If it is activated, the input is used as a normally closed contact. r7 = Reopen while closing (sensitive edge with 8K2 resistor). r8 = Reclose while opening (sensitive edge with 8K2 resistor). Partial opening Open Close Step-by-step - The first command is to open and the second to close. Sequential - The first command is to open, the second to STOP, the third to close and the fourth to STOP.	The function allows you to configure the inputs on the I/O modules.  The function only appears if there is a BUS I/O module connected.



Path: CONFIGURATION > BUS DEVICES > I/O MODULE BUS 1 > **Light output**

Path: CONFIGURATION > BUS DEVICES > I/O MODULE BUS 2 > **Light output**

<b>Light output</b>	<p>Passage-open warning light - It notifies the user of the operator status.</p> <p> See function [Passage-open warning light].</p> <p>Cycle lamp - The lamp stays on during the manoeuvre.</p> <p>Courtesy light - The light switches on when a manoeuvre starts and remains on once the manoeuvre has finished, for the time set under the [Courtesy time] function.</p>	<p>This function allows you to configure output 1 on the I/O modules.</p> <p> The function only appears if there is a BUS I/O module connected.</p>
---------------------	---	--

Path: CONFIGURATION > BUS DEVICES > I/O MODULE BUS 1 > **Relay output**

Path: CONFIGURATION > BUS DEVICES > I/O MODULE BUS 2 > **Relay output**

<b>Relay output</b>	<p>User command (Default): the output is managed by user commands or timers</p> <p>AMF (Access Management Function) – The output is used to indicate the fully open passage position in AMF mode.</p> <p> The output remains open when the gate is fully open and remains closed in all other cases.</p>	<p>Associate a function with I/O module output 2.</p> <p> The function only appears if there is a BUS I/O module connected.</p>
---------------------	---	--

Path: CONFIGURATION > BUS DEVICES > I/O MODULE BUS 1 > **Relay output time**

Path: CONFIGURATION > BUS DEVICES > I/O MODULE BUS 2 > **Relay output time**

<b>Relay output time</b>	<p>Bistable</p> <p>ON - 1 to 180 seconds (Default 1)</p>	<p>The function allows you to associate a time with output 2 on the I/O modules.</p> <p> The function only appears if there is a BUS I/O module connected.</p>
--------------------------	--	---

### BUS flashing beacon

Path: CONFIGURATION > BUS DEVICES > BUS FLASHING BEACON > **Opening colour**

<b>Opening colour</b>	<p>White</p> <p>Yellow</p> <p>Orange</p> <p>Red (Default)</p> <p>Purple</p> <p>Blue</p> <p>Light blue</p> <p>Green</p>	<p>This function allows you to set the colour of the BUS flashing beacon during operator opening.</p> <p> The function only appears if there is a BUS flashing beacon connected.</p>
-----------------------	--	---

*Path:* CONFIGURATION > BUS DEVICES > BUS FLASHING BEACON > **Closing colour**

<b>Closing colour</b>	White Yellow Orange Red (Default) Purple Blue Light blue Green	This function allows you to set the colour of the BUS flashing beacon during operator closing.  The function only appears if there is a BUS flashing beacon connected.
-----------------------	---	--



*Path:* CONFIGURATION > BUS DEVICES > BUS FLASHING BEACON > **Auto. cl. colour**

<b>Automatic closing time colour</b>	Off White Yellow Orange Red Purple Blue Light blue Green (Default)	The function allows you to set the BUS flashing beacon colour during the automatic closing time.  The function only appears if there is a BUS flashing beacon connected.
--------------------------------------	--	--

*Path:* CONFIGURATION > BUS DEVICES > BUS FLASHING BEACON > **Pre-flashing colour**

<b>Pre-flashing colour</b>	White (Default) Yellow Orange Red Purple Blue Light blue Green	The function allows you to set the flash colour for before opening and closing manoeuvres (pre-flash).  The function only appears if there is a BUS flashing beacon connected.
----------------------------	---	--

*Path:* CONFIGURATION > BUS DEVICES > BUS FLASHING BEACON > **Signal error**

<b>Signal error</b>	Deactivated (Default) White Yellow Orange Red Purple Blue Light blue Green	The function allows you to set the colour of the BUS flashing beacon in the event of an error signal.  The warning light is activated after sending a command for movement.  The function only appears if there is a BUS flashing beacon connected.
---------------------	--	---

## BUS device lights

*Path:* CONFIGURATION > BUS DEVICES > BUS DEVICE LIGHTS > **Signal maintenance**

<b>Signal maintenance</b>	Deactivated (Default)	The function allows you to set the colour of the flash on enabled BUS devices (flashing beacons and selectors) when maintenance is necessary. With the function activated, these devices will signal that maintenance needs to be carried out at the start of each manoeuvre. <b>Configure maintenance and set the number of manoeuvres. See function [Configure maintenance].</b>  <b>The function only appears if there is a BUS flashing beacon or a BUS selector connected.</b>
	White Yellow Orange Red Purple Blue Light blue Green	

## Command inputs

*Path:* CONFIGURATION > COMMAND INPUTS > **Command 2-7**

<b>Command 2-7</b>	Step-by-step (Default) - The first command is to open and the second to close.	The function associates a command to the device connected on 2-7.
	Sequential - The first command is to open, the second to STOP, the third to close and the fourth to STOP.	

## Functions

*Path:* CONFIGURATION > FUNCTIONS > **Removing obstacles**

<b>Removing obstacles</b>	Deactivated (Default) - When an obstacle is detected, the operator inverts the direction of travel until the limit switch is reached.	The function allows you to activate the Remove obstruction mode where an obstacle is detected.
	Activated - When an obstacle is detected, the operator inverts the direction of travel to create enough space to clear the obstacle and then comes to a stop.	

*Path:* CONFIGURATION > FUNCTIONS > **B1-B2 output function**

<b>B1-B2 output function</b>	User command (Default): the output is managed by user commands or timers	The function configures the contact B1-B2.
	AMF: passage open - Access Management Function. The output is used to indicate the fully open passage position in AMF mode. <b>The output remains open when the gate is fully open and remains closed in all other cases.</b>	





*Path:* CONFIGURATION > FUNCTIONS > **Hold-to-run**

<b>Hold-to-run</b>	Deactivated (Default) On	With the function active, the operator stops moving (opening or closing) when the control device is released.  <b>When the function is active, it excludes all other control devices.</b>
--------------------	-----------------------------	---

*Path:* CONFIGURATION > FUNCTIONS > **Obst. with motor stopped**

<b>Obstacle with motor stopped</b>	Disabled (Default) On	With the function active and the operator stopped, an open or close command is not performed if the safety devices detect an obstacle. The function is active when the passage is closed or open, or after a complete stop.
------------------------------------	--------------------------	---

Path: CONFIGURATION > FUNCTIONS > Standby mode

<p><b>Low consumption in standby mode</b></p>	<p>Off</p> <p><b>From closed</b> - Low consumption active in standby mode with gate closed The function activates after 3 minutes of operator inactivity with the gate closed.</p> <p> If there is a courtesy light, standby mode activates 3 minutes after the light switches off.</p> <p><b>From stationary (Default)</b> - Low consumption always active in standby mode The function activates after 3 minutes of gate inactivity.</p> <p> If there is a courtesy light, standby mode activates 3 minutes after the light switches off.</p>	<p>The function is used to start operator standby mode. In standby mode, operator consumption is reduced as per Regulation (EU) 2023/826.</p> <p>In standby mode and with the function active, the power supply to the accessories (output 10-11) is deactivated. If the control devices need to remain active at all times, deactivate the function.</p> <p> When the control panel is in standby mode, the display shows [STANDBY].</p> <p> The function is only available with the Green Power module installed (806XG-0160).</p>
---	---	--

**Devices connected with BUS CXN**

With at least one device connected to the CXN bus, the control panel enters [Networked standby] mode as required by Regulation (EU) 2023/826.

The display message [STANDBY NOT POSSIBLE] indicates that the control panel is unable to switch to standby mode because the Green Power module cannot support the consumption of all connected accessories. Turn standby mode off or reduce the number of connected accessories.

**How to check the number of accessories that can be managed with the Green Power module in standby mode**

Scan the QR code below or click the link and follow the instructions to check the overall consumption of the connected accessories.

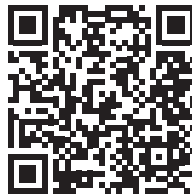

**Times**

Path: CONFIGURATION > TIMES > Automatic close

<p><b>Automatic closure</b></p>	<p>Deactivated (Default) From 1 to 180 seconds</p>	<p>The function is used to set the time before automatic closure, once the opening travel end point has been reached or once the photocells have caused a partial stop [C3].</p> <p> The function does not work if any of the safety devices are triggered when an obstacle is detected, after a complete stop, during a power outage or if there is an error.</p>
---------------------------------	--	---

*Path:* CONFIGURATION > TIMES > **Automatic partial close**

<b>Automatic closing after partial opening</b>	Off 1 to 180 seconds (Default 10)	The function is used to set the time before automatic closure after a partial opening command has been performed or after the photocells have caused a partial stop [C3].  The function does not work if any of the safety devices are triggered when an obstacle is detected, after a complete stop, during a power outage or if there is an error.
--	--------------------------------------	--

### Apartment building mode

With the Partial Opening command (2-3P), the leaf M2 opens.

If an Open command (2-3) is then sent, both leaves open.

With the [Automatic closing] function set, leaf M1 closes after the selected automatic closing time, while leaf M2 moves to the partial opening point set under [Partial opening adjustment].

 If the partial opening command is given from input (2-3P), the [Automatic closing after either partial or pedestrian opening] function must be deactivated.

 To return to normal gate operation, send a closing command.

 If the partial opening command is sent via a timer, after the set time the operator returns to normal operation and the leaves close. See function [Create timer].

*Path:* CONFIGURATION > TIMES > **B1-B2 output time**

<b>B1-B2 output time</b>	Bistable Monostable: on from 1 to 180 seconds (Default 1)	The function is used to set the B1-B2 output as bistable or monostable. Where the output is monostable, the contact closing time can be chosen.
--------------------------	--	---

## Manage lights

*Path:* CONFIGURATION > MANAGE LIGHTS > **Passage-open warning light**

<b>Passage-open warning light</b>	Warning light on (Default) - The light stays on when the operator is moving or the passage is open.  Warning light flashing - The warning light flashes every half a second when the passage is opening and stays on when the passage is open. The light flashes every second when the passage is closing, and remains off when the passage is closed.	The function is used to set the type of warning for the open passage light.
-----------------------------------	--	---

<i>Path:</i> CONFIGURATION > MANAGE LIGHTS > <b>Light E3</b>		
<b>Additional light</b>	<p>Disabled (Default) Cycle lamp - The lamp stays on during the manoeuvre.</p> <p> An automatic closing time must be set under [Automatic closing] to ensure correct operation.</p> <p>Courtesy light - The light switches on when a manoeuvre starts and remains on once the manoeuvre has finished, for the time set under the [Courtesy time] function.</p>	This function allows you to choose the operating mode of the lighting device connected to the output E3.

<i>Path:</i> CONFIGURATION > MANAGE LIGHTS > <b>Courtesy time</b>		
<b>Courtesy light time</b>	60 to 180 seconds (Default 60)	The function allows you to set the seconds the additional light (set up as courtesy light) stays on after an opening or closing manoeuvre.

<i>Path:</i> CONFIGURATION > MANAGE LIGHTS > <b>Pre-flashing time</b>		
<b>Pre-flashing time</b>	Deactivated (Default) 1 to 10 seconds	The function adjusts the time for which the beacon is activated before each manoeuvre.

## RSE communication

<i>Path:</i> CONFIGURATION > RSE COMMUNICATION > <b>RSE1</b>		
<b>RSE communication - RSE1</b>	CRP (Default) Paired	The function is used to configure the card inserted in the RSE1 connector.

<i>Path:</i> CONFIGURATION > RSE COMMUNICATION > <b>RSE2</b>		
<b>RSE communication - RSE2</b>	CRP (Default) RTU MODBUS	The function is used to configure the card inserted in the RSE2 connector.

<i>Path:</i> CONFIGURATION > RSE COMMUNICATION > <b>CRP address</b>		
<b>CRP address</b>	1 to 254 (Default 1)	<p>The function assigns a unique identification code (CRP address) to the control board.</p> <p> The function is used where there are multiple operators connected to the same communication BUS using the CRP protocol.</p>

<i>Path:</i> CONFIGURATION > RSE COMMUNICATION > <b>RSE1 speed / RSE2 speed</b>		
<b>RSE1 speed</b> <b>RSE2 speed</b>	<p>4800 bps</p> <p>9600 bps</p> <p>14400 bps</p> <p>19200 bps</p> <p>38400 bps (Default)</p> <p>57600 bps</p> <p>115200 bps</p>	The function is used to set the remote connection system communication speed on the RSE1 and RSE2 port.

## External memory

*Path:* CONFIGURATION > EXTERNAL MEMORY > **Save data**

### Save data

The function activates saving user data, timings and configurations to the memory device (memory roll).

*Path:* CONFIGURATION > EXTERNAL MEMORY > **Read data**

### Read data

The function activates uploading user data, timings and configurations on the memory device (memory roll). Any configurations already on the electronic board are overwritten.

## Parameter reset

*Path:* CONFIGURATION > **Parameter reset**

### Parameter reset

Confirm? NO  
Confirm? YES

The function restores the factory configurations except for: [users], [password], [motor type], [CRP address], [RSE speed], [language], and the travel calibration settings.

## Guided procedure (Wizard)

*Path:* CONFIGURATION > **Guided procedure (Wizard)**

### Guided procedure (Wizard)

The function is used to launch the system configuration wizard.

## User management

### New user

*Path:* USER MANAGEMENT > **New user**

### New user

The function is used to register up to a maximum of 1000 users and assign a function to each one.

 The operation can be carried out using a transmitter or a BUS selector device (e.g. a keypad or transponder reader). The board that manages the transmitters (AF) must be inserted into the connector.

 See the [Saving a new user] section for information on the save procedure.

### Remove user

*Path:* USER MANAGEMENT > **Remove user**

### Remove user

The function is used to remove one of the registered users.

 See the [Remove registered users] section for information on how to remove them.

### Remove all

*Path:* USER MANAGEMENT > **Remove all**

### Remove all

The function is used to remove all registered users.

## Radio decoding

Path: USER MANAGEMENT > Radio decoding

<b>Radio decoding</b>	All decoding (Default) Rolling code TW Key block	The function is used to choose the type of radio coding for the transmitters enabled to control the operator.  📖 If you choose [Rolling code] or [TW key block], any transmitters with a different type of radio coding saved previously will be deleted.
-----------------------	--	---

## Self-Learning Rolling

Path: USER MANAGEMENT > Self-Learning Rolling

<b>Self-Learning Rolling</b>	Deactivated (Default) On	The function is used to save a new rolling code transmitter by activating acquisition from a rolling code transmitter that has already been stored. The saving and acquisition procedures are explained in the transmitter manual.
------------------------------	-----------------------------	--

## Change mode

Path: USER MANAGEMENT > Change mode

<b>Change mode</b>	Change the function assigned to a specific user.  📖 For more information about the procedure, see the [Change a command assigned to a user] section.
--------------------	--

## Information

### FW version

Path: INFORMATION > FW version

<b>FW version</b>	Use the < > arrows to show: FW x.x.xx (firmware) GUI x.x (graphics) MOT x.x.xx (motor)	The function is used to display the firmware version and the GUI installed.
-------------------	---	---

### BUS device status

Path: INFORMATION > BUS device status

<b>BUS device status</b>	BUS 1-8 photocell BUS 1-8 selector switch BUS 1 / 2 flashing beacon I/O BUS 1 / 2 module	The function shows the status of all devices that can be connected to the BUS and managed by the firmware in use.  <b>Available device statuses:</b> - OK - Not communicating - Safety device active - BUS address conflict
--------------------------	---	---

## Manoeuvre counter

*Path:* INFORMATION > **Manoeuvre counter**

<b>Manoeuvre counter</b>	Total manoeuvres - Manoeuvres performed since the operator was installed. Partial manoeuvres - Manoeuvres carried out after the last maintenance.	The function allows you to view the number of total or partial operator manoeuvres (after maintenance).
--------------------------	--	---

## Configure maintenance

*Path:* INFORMATION > **Maintenance conf.**

<b>Configure maintenance</b>	Deactivated (Default) from 1 x100 to 500 x100	The function allows you to set the number of manoeuvres the operator can perform before a maintenance warning signal is generated.  The warning is displayed as a [Maintenance required] message and signalled by 3 + 3 flashes every hour on the device [Passage-open warning light].
------------------------------	--	--

## Maintenance reset

*Path:* INFORMATION > **Maintenance reset**

<b>Maintenance reset</b>	The function allows you to reset the number of partial manoeuvres.
--------------------------	--

## Errors list

*Path:* INFORMATION > **Errors list**

<b>Errors list</b>	The function allows you to view the last 8 errors detected. The error list can be deleted. Use the arrows to scroll through the list. To cancel the error list, select [Delete errors] Press ENTER to confirm.
--------------------	---

## Timer management

### Show clock

*Path:* TIMER MANAGEMENT > **Show clock**

<b>Show clock</b>	The function is used to enable the clock on the display.
-------------------	--

### Set the clock

*Path:* TIMER MANAGEMENT > **Set the clock**

<b>Set the clock</b>	The function is used to set the date and time. Use the arrows and the Enter button to enter the desired values.
----------------------	--

## Automatic DST

*Path:* TIMER MANAGEMENT > **Automatic DST**

<b>Automatic DST</b>	<p>Deactivated (Default) On Summer changeover: +1 hour on the last Sunday in March (change to daylight saving time). Winter changeover: -1 hour on the last Sunday in October (change to standard time).</p>	<p>The function allows you to enable automatic daylight saving time setting.</p> <p> <b>Valid in Central Europe only UTC+1.</b></p>
----------------------	--	--

## Time format

*Path:* TIMER MANAGEMENT > **Time format**

<b>Time format</b>	<p>24-hour 12-hour</p>	<p>The function allows you to choose the clock display format.</p>
--------------------	----------------------------	--

## Create new timer

*Path:* TIMER MANAGEMENT > **Create new timer**

<b>Create new timer</b>	<p>The function allows you to time one or more types of activation chosen from those available.</p> <p> For more information about the procedure, see the [Creating a new timer] section.</p>
-------------------------	--

## Remove timer

*Path:* TIMER MANAGEMENT > **Remove timer**

<b>Remove timer</b>	<p>Use the arrows to choose the timing to be removed. O = [Opening] P = [Partial opening] B = [Output B1-B2] R = [BUS module relay] Press ENTER to confirm.</p>	<p>The function allows you to remove one of the saved timings.</p>
---------------------	---	--

## Language

*Path:* LANGUAGE

<b>Language</b>	<p>Italiano (IT) English (EN) (Default) Français (FR) Deutsch (DE) Español (ES) Português (PT) Русский (RU) Polski (PL) Românesc (RO) Magyar (HU) Hrvatski (HR) Український (UA) Nederlands (NL) Slovenský (SK)</p>	<p>The function allows you to set the display language.</p>
-----------------	---	---

## Password

### Enable password

---

*Path:* PASSWORD > **Enable password**

#### Enable password

The function allows you to set a 4-digit password. The password will be requested to anyone who wants to access the main menu.

 This option only shows if a password has NOT been enabled.

Use the arrows and the Enter button to dial the desired code.

Enter the password again using the arrows and the Enter button to confirm.

### Remove password

---

*Path:* PASSWORD > **Remove password**

#### Remove password

The function allows you to remove the password that protects access to the main menu.

 This option only shows if a password has been enabled.

### Change password

---

*Path:* PASSWORD > **Change password**

#### Change password

The function allows you to change the password that protects access to the main menu.

 This option only shows if a password has been enabled.

Use the arrows and the Enter button to dial the desired code.

Enter the password again using the arrows and the Enter button to confirm.

## Forgotten password

---

If you lose the password, you will need to reset the board to its factory settings. See [Factory reset].

### Factory reset

---

To restore the electronic board data to factory settings:

Disconnect the control board from the power supply and wait for it to switch off.

Press and hold the < and > buttons, then reconnect the control board to the power supply.

Continue to press and hold the < > buttons until [Factory reset] is displayed.

Select [Confirm? YES]

Press **ENTER** to confirm.

 When you reset the control board, all saved users, set times, manoeuvre configurations and calibration operations are deleted.

## Saving a new user

---

Press **ENTER** to enter programming.

Access: [USER MANAGEMENT] > **New user**

Press **ENTER** to confirm.

Choose the function to be assigned to the user:

Step-by-step - The first command is to open and the second to close.

Sequential - The first command is to open, the second to STOP, the third to close and the fourth to STOP.

Open

Partial opening

B1-B2 output

BUS 1 module relay - Activate output 2 (relay output) on BUS 1 I/O module

BUS 2 module relay - Activate output 2 (relay output) on BUS 2 I/O module

You will be asked to enter your user code. Send the code from the control device within 10 seconds.

 The operation can be carried out by using a transmitter or a BUS selector device (e.g. a keypad or transponder reader).

The board that manages the control devices (AF) must be inserted into the connector.

Repeat the procedure to add other users.

## Removing a registered user

---

Press **ENTER** to enter programming.

Access: [USER MANAGEMENT] > **Remove user**

Press **ENTER** to confirm.

Use the arrows to choose the number associated with the user you want to remove and press **ENTER** to confirm.

 Alternatively, the control device associated with the user you want to remove can be activated.

A confirmation request appears on the display:

Confirm? NO

Confirm? YES

Select [Yes] using the arrows and press **ENTER** to confirm deletion.

Repeat the procedure to remove other users.

## Change a command assigned to a user

---

Press **ENTER** to enter programming.

Access: [USER MANAGEMENT] > **Change mode**

Press **ENTER** to confirm.

Use the arrows to choose the number associated with the user you want to edit. Press **ENTER** to confirm.

 **Alternatively, the control device associated with the user you want to remove can be activated.**

Choose the new command to associate with the user:

Step-by-step - The first command is to open and the second to close.

Sequential - The first command is to open, the second to STOP, the third to close and the fourth to STOP.

Open

Partial opening

B1-B2 output

BUS 1 module relay - Activate output 2 (relay output) on BUS 1 I/O module

BUS 2 module relay - Activate output 2 (relay output) on BUS 2 I/O module

Confirm? NO

Confirm? YES

Press **ENTER** to confirm.

A confirmation request appears on the display:

Confirm? NO

Confirm? YES

Select [Yes] using the arrows and press **ENTER** to confirm your choice.

Repeat the procedure to edit other users.

## Creating a new timer

You can create up to 8 timers and 16 special days. Special days are exceptions to the weekly schedule. They refer to a specific day (e.g. a bank holiday). Special days can only be set from the CAME app [CONNECT SetUp].

**Wired commands always take priority over commands set on the timer. Commands set on the timer take priority over commands forwarded by registered users (selectors and transmitters).**

Example:

- The wired command connected to terminal 2-4 closes the operator even if the timer is set to [Opening].
- A closing command sent from the transmitter of a registered user is not performed by the gate if the timer is set to [Opening].

Press **ENTER** to enter programming.

Path: **TIMER MANAGEMENT > Create new timer**

Use the arrows to choose the command to associate with the timer:

- Open
- Partial opening
- B1-B2 output
- BUS 1 module relay - Activate output 2 (relay output) on BUS 1 I/O module
- BUS 2 module relay - Activate output 2 (relay output) on BUS 2 I/O module

Press **ENTER** to confirm.

Start time

Use the arrows to set the command activation time. Press **ENTER** to confirm.

End time

Use the arrows to set the command deactivation time. Press **ENTER** to confirm.

- Select days
- All week

- Press [Select days] to choose one or more days of the week individually.
- Press [All week] to select the whole week.

Press **ENTER** to confirm.

Repeat the procedure to set other timers.

### How to add a timer over two days

Create two single timers as specified in the above procedure.

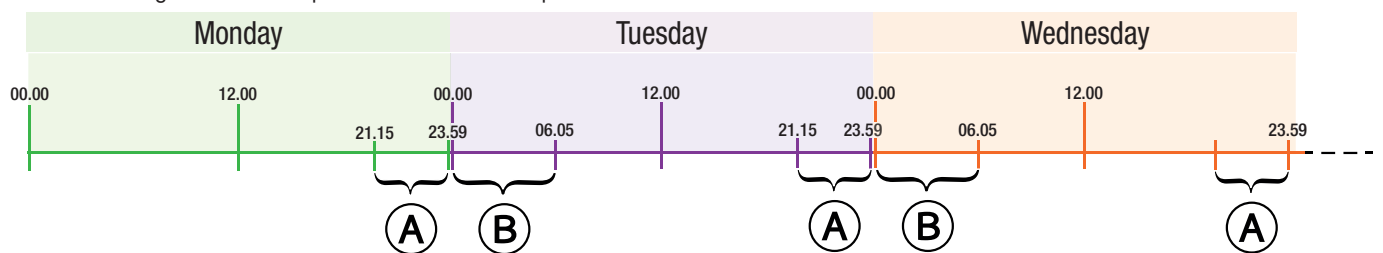

**A** = First timer

**B** = Second timer

## Import/export data

Save user data and system configuration data on a MEMORY ROLL card.

The stored data can be reused for another control board of the same type to carry across the same configuration.

⚠ Before inserting and removing the MEMORY ROLL card, DISCONNECT THE MAINS POWER SUPPLY TO THE LINE.

- 1 Insert the MEMORY ROLL card into the corresponding connector on the control board.
- 2 Press the “Enter” button to access programming.
- 3 Use the arrows to choose the desired function.

📖 The functions are displayed only when a MEMORY ROLL card is inserted.

*Path:* CONFIGURATION > EXTERNAL MEMORY > **Save data**

<b>Save data</b>	Save user data, timings and configurations to the memory device (memory roll).
------------------	--

*Path:* CONFIGURATION > EXTERNAL MEMORY > **Read data**

<b>Read data</b>	Upload user data, timings and configurations to the memory device (memory roll).
------------------	--

📖 Once the data have been saved and loaded, remove the MEMORY ROLL card.

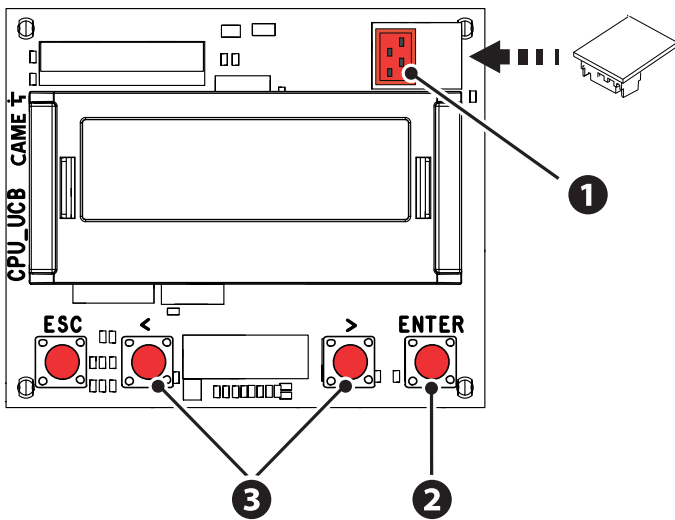

## PAIRED OPERATION

Two connected operators are controlled with one command.

### Electrical connections

Connect the two electronic boards with a UTP CAT 5 cable.

Insert an RSE card into both control boards.

Connect up the electrics for the devices and accessories.

📖 The devices and accessories must be connected to the control board which will be set as the MASTER.

📖 For information on connecting the electrics for the devices and accessories, please see the “ELECTRICAL CONNECTIONS” section.

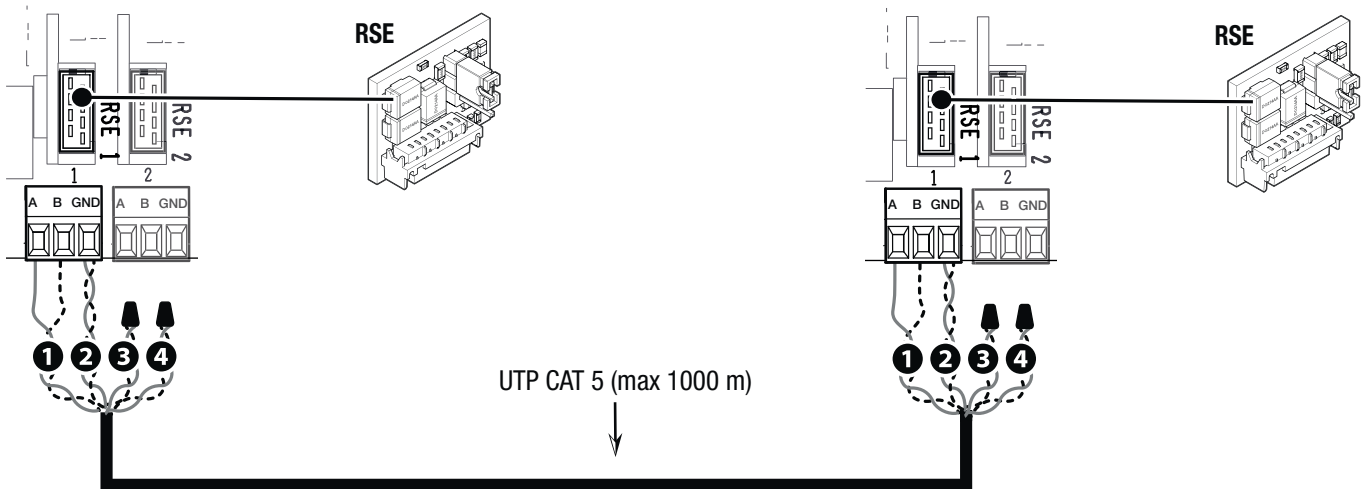

### Programming

📖 All programming operations described below must be performed only on the control board set as the MASTER. Select the [Paired] system type when following the guided procedure, or configure the RSE\_1 port to [Paired] mode.

📖 After programming the MASTER operator in [Paired], the second operator automatically becomes SLAVE.

### Saving users







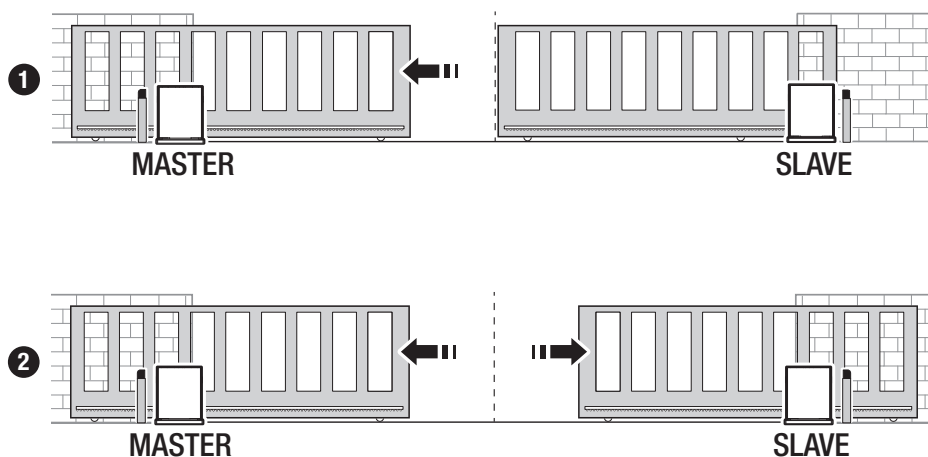







📖 All save user operations must be performed only on the control board set as the MASTER.

### Operating modes

- ❶ PARTIAL OPENING command
- ❷ STEP-BY-STEP command



## DISPLAY WARNINGS KEY

	The [Impact test] function is on.
	The operator detected an obstruction when the gate was moving to the right.
	The operator detected an obstruction when the gate was moving to the left.
	The operator detected two obstructions when the gate was moving to the right.  The number on the display varies according to the number of obstructions detected.  When the maximum number of detected obstructions has been reached, the operator stops and an error message shows on the display.
	The operator detected two obstructions when the gate was moving to the left.  The number on the display varies according to the number of obstructions detected.  When the maximum number of detected obstructions has been reached, the operator stops and an error message shows on the display.
	There is at least one programmed timer.
	A programmed timer is running.  With the timer programmed for opening or partial opening, any given radio command will always allow opening. The wired commands continue to operate normally.
<b>C0</b>	Total stop active
<b>i3</b>	2-3 command input active
<b>i3p</b>	2-3P command input active
<b>i4</b>	2-4 command input active
<b>C&lt;n&gt;</b>	Wired safety device active  The <n> value is associated with the selected parameter for the functions [CX input] [CY input] [CZ input] [CK input].
<b>i7</b>	2-7 command input active
<b>r7</b>	R7 safety device (sensitive edge) active
<b>r8</b>	R8 safety device (sensitive edge) active
<b>2r7</b>	R7 safety device (pair of sensitive edges) active
<b>2r8</b>	R8 safety device (pair of sensitive edges) active
<b>c&lt;n&gt;</b>	BUS photocell safety device active  The <n> value is associated with the selected parameter for the [BUS photocell] functions.
<b>c23</b>	Open command active for BUS photocells
<b>c24</b>	Close command active for BUS photocells
<b>P&lt;n&gt;</b>	RIO safety device active  The <n> value is associated with the selected parameter for the functions [RIO ED T1 - RIO ED T2] and [RIO PH T1 - RIO PH T2]

<b>OP</b>	Passage fully open
<b>CL</b>	Passage fully closed
<b>BUS address conflict</b>	ID conflict detected on BUS devices.
<b>Check BUS device</b>	No BUS device with a safety function configured.
<b>RIO not configured</b>	The RIO Conn board is not configured or has no safety configuration.
<b>Calibration needed</b>	Travel calibration required.
<b>Guided procedure (Wizard)</b>	Follow the on-screen wizard.
<b>Maintenance required</b>	Maintenance required (manoeuvres exceeded for maintenance).

## ERROR MESSAGES

<b>E2</b>	Calibration error
<b>E4</b>	Motor failure error
<b>E6</b>	Motor not working
<b>E7</b>	Operating time error
<b>E8</b>	Open release-hatch error
<b>E9</b>	Obstacle detected during closing
<b>E10</b>	Obstacle detected during opening
<b>E11</b>	The maximum number of obstacles detected consecutively has been exceeded
<b>E12</b>	Motor supply voltage missing or insufficient
<b>E13</b>	Limit switch input error or both limit switches open
<b>E14</b>	Serial communication error in paired mode
<b>E15</b>	Incompatible transmitter error
<b>E17</b>	Wireless system (RIO) communication error
<b>E18</b>	Wireless system (RIO) not configured error
<b>E24</b>	Communication error or malfunction of a BUS safety device
<b>E25</b>	Address settings error on BUS devices
<b>E27</b>	Communication error with motor

Models	BKX12AGM	BKX12RGM
Length - Weight	20 m - 1200 kg	20 m - 1200 kg
Cycles	250000	250000
Installation in windy area (%)	-15	-15
Full leaf door (%)	-15 %	-15 %
Full leaf door installed in windy area (%)	-30 %	-30 %

- 📖 The percentages indicate how much the number of cycles should be reduced in relation to the type of installation.
- ⚠ Before carrying out any cleaning or maintenance, or replacing any parts, disconnect the device from the power supply.
- ⚠ This document informs the installer of the checks that must be carried out during maintenance.
- ⚠ If the system is not used for long periods of time, e.g. for installations at sites with seasonal closures, disconnect the power supply. When the power supply is reconnected, check the system is working correctly.
- 📖 For information on correct installation and adjustments, please see the product installation manual.
- 📖 For information on choosing products and accessories, please see our product catalogue.
- 📖 Every 10,000 cycles and, in any case, every 6 months of operation, you must perform the maintenance work indicated below.

Perform a general and complete check of the tightness of the nuts and bolts.  
 Grease all of the moving mechanical parts.  
 Check the warning and safety devices are working properly.  
 Check for any wear on the moving mechanical parts and check that they are working properly.  
 Check the release mechanism is working efficiently by performing a manoeuvre with the leaf free. The gate leaf must not be obstructed.  
 Check the cables are intact and connected correctly.  
 Check and clean the track guide and rack.

## FINAL OPERATIONS

- 📖 Before closing up the casing, check that the cable inlets are sealed to stop insects getting in and to prevent damp.

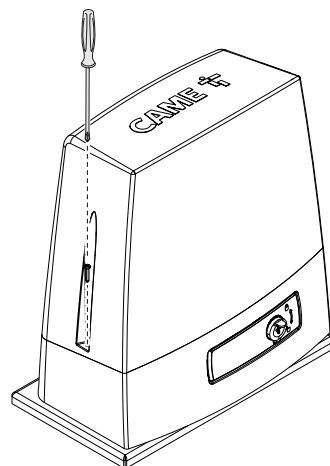
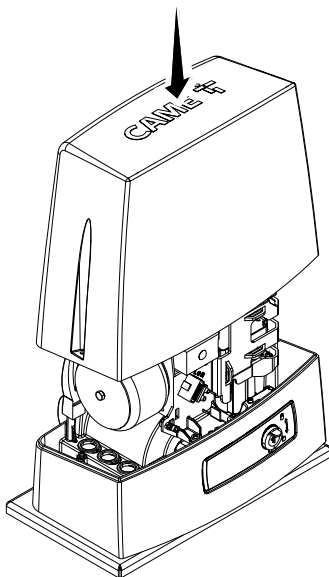







[CAME.COM](http://CAME.COM)

**CAME S.P.A.**

Via Martiri della Libertà, 15

31030 Dosson di Casier

Treviso - Italy

Tel. (+39) 0422 4940

Fax (+39) 0422 4941

[info@came.com](mailto:info@came.com) - [www.came.com](http://www.came.com)

**AFFIX THE PRODUCT LABEL  
FROM THE BOX HERE**