



FAAC para la naturaleza  
100% papel reciclado



FAAC ist  
100% umweltfreundlich



FAAC pour la nature  
papier recyclé 100%



FAAC for nature  
recycled paper 100%



FAAC per la natura  
carta riciclata 100%



# 593

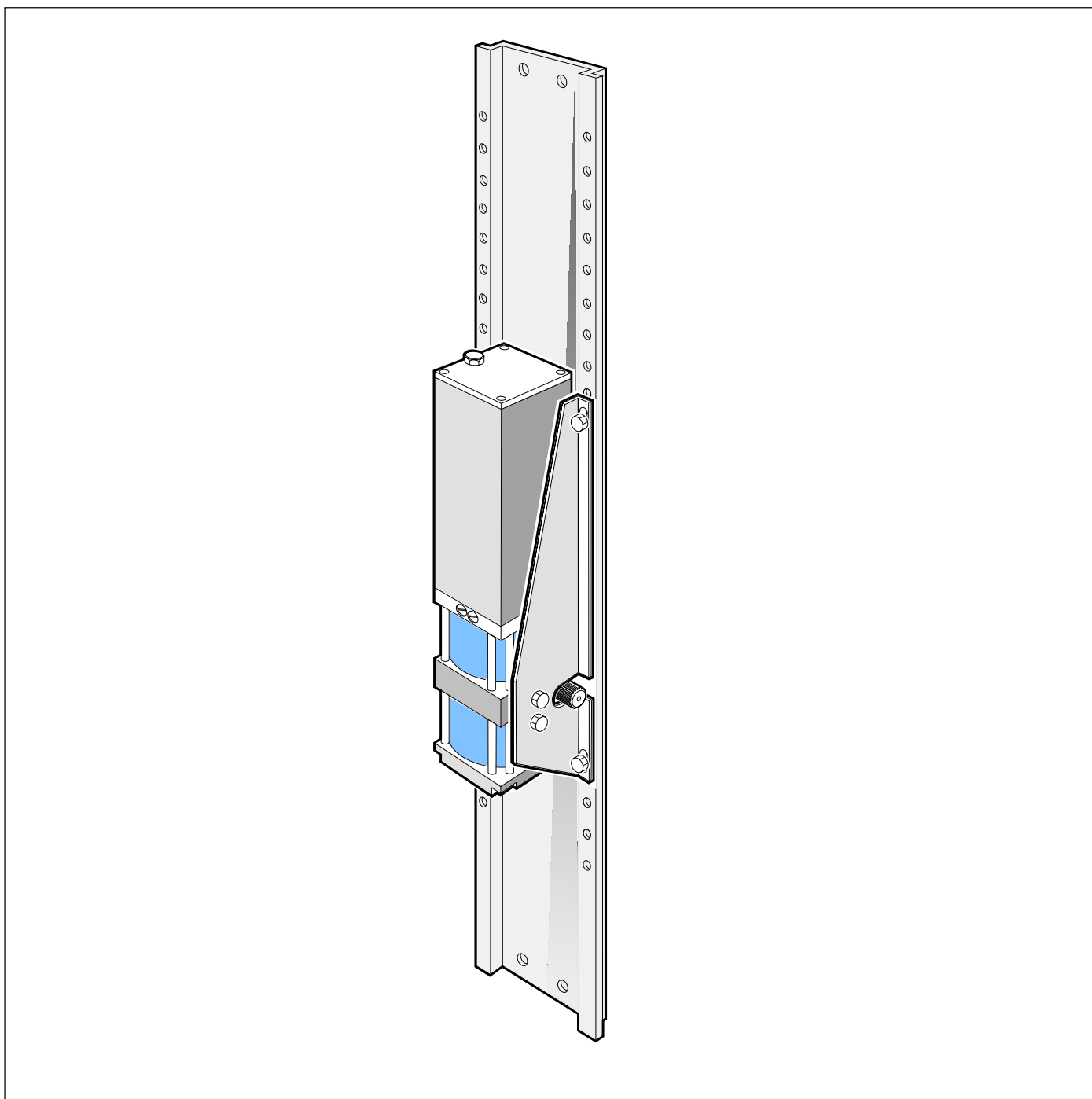

# FAAC



UNI EN ISO 9001-085

**EC MACHINE DIRECTIVE COMPLIANCE DECLARATION**

(DIRECTIVE 89/392 EEC, APPENDIX II, PART B)

**Manufacturer:** FAAC S.p.A.

**Address:** Via Benini, 1  
40069 - Zola Predosa  
BOLOGNA - ITALY

**Hereby declares that:** the 593 automation system

- is intended to be incorporated into machinery, or to be assembled with other machinery to constitute machinery in compliance with the requirements of Directive 89/392 EEC, and subsequent amendments 91/368 EEC, 93/44 EEC and 93/68 EEC;
- complies with the essential safety requirements in the following EEC Directives:  
  
73/23 EEC and subsequent amendment 93/68 EEC.  
89/336 EEC and subsequent amendments 92/31 EEC and 93/68 EEC.

and furthermore declares that unit must not be put into service until the machinery into which it is incorporated or of which it is a component has been identified and declared to be in conformity with the provisions of Directive 89/392 EEC and subsequent amendments enacted by the national implementing legislation.

Bologna, 1 January 1997

Managing  
Director

A. Bassi

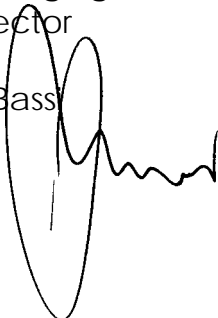
A handwritten signature in black ink, appearing to be 'A. Bassi', written over the printed name. The signature is stylized with a large loop at the beginning and a wavy tail.

# IMPORTANT NOTICE FOR THE INSTALLER

## GENERAL SAFETY REGULATIONS

- 1) **WARNING! FAAC strongly recommends to follow these instructions literally for the safety of persons. Improper installation or misuse of the product will cause very serious damages to persons.**
- 2) Packaging material (plastic, polystyrene etc.) is a potential hazard and must be kept out of reach of children.
- 3) Read the instructions carefully before installing the product.
- 4) Keep these instructions for future reference.
- 5) This product has been designed and manufactured only for the use stated in this manual. Any other use not expressly set forth will affect the reliability of the product and/or could be source of hazard.
- 6) FAAC S.p.A. cannot be held responsible for any damage caused by improper use or different from the use for which the automation system is destined to.
- 7) Do not use this device in areas subject to explosion: the presence of flammable gas or fumes is a serious hazard.
- 8) Mechanical constructive elements must comply with UNI8612, CEN pr EN 12604 and CEN pr EN 12605 standards. Countries outside the EC shall follow the regulations above besides their national normative references in order to offer the utmost safety.
- 9) FAAC cannot be held responsible for failure to observe technical standards in the construction of gates and doors, or for any deformation of the gates which may occur during use.
- 10) Installation must comply with UNI8612, CEN pr EN 12453 and CEN pr EN 12635.  
The degree of safety of the automation must be C+E.
- 11) Before carrying out any operations, turn off the system's main switch.
- 12) An omnipower switch shall be provided for the installation with an opening distance of the contacts of 3 mm or more. Alternatively, use a 6A thermomagnetic breaker with multi-pole switching.
- 13) Ensure that there is a differential switch up-line of the electrical system, with a trip threshold of 0.03A.
- 14) Check that the earthing plant is in perfect condition and connect it to the metallic parts. Also earth the yellow/green wire of the operator.
- 15) The automation is fitted with an anti-crush safety system that is a torque control device. In any case, further safety devices shall be installed.
- 16) The safety devices (e.g. photocells, safety edges, etc.) protect areas where there is a mechanical movement hazard, e.g. crushing, entrapment and cutting.
- 17) Each installation must be fitted with at least one flashing light (e.g. FAAC LAMP, MINILAMP etc.) as well as a warning plate suitably fixed to the gate, besides the safety devices as per point 16. above.
- 18) FAAC cannot be held responsible regarding safety and correct functioning of the automation in the event that parts other than FAAC original parts are used.
- 19) Use only FAAC original spare parts for maintenance operations.
- 20) Do not carry out any modifications to automation components.
- 21) The installer must supply all information regarding manual operation of the system in the event of an emergency and provide the end-user with the "End-user Guide" attached to the product.
- 22) Keep out of persons when the product is in operation.
- 23) Keep out of reach of children the remote radio controls and any control devices. The automation could be operated unintentionally.
- 24) The end-user must avoid any attempt to repair or adjust the automation personally. These operations must be carried out exclusively by qualified personnel.
- 25) **What is not explicitly stated in these instructions is not permitted.**

# THE 593 AUTOMATION SYSTEM

The 593 automation system is a hydraulic unit formed of a motor pump and a piston-rack assembly, which ensures optimal automation of up-and-over garage doors. It is mounted on the door by means of accessories.

The system has an adjustable anti-crushing safety system, a device that stops and locks the door in any position, and a convenient manual release device to be used in the event of a power failure or malfunction.

The 593 automation system has been designed and manufactured for the automation of counterbalanced up-and-over doors. Figures 1, 2 and 3 show the most commonly used types of doors. No other use of the system is allowed.

## 1. DESCRIPTION AND TECHNICAL CHARACTERISTICS

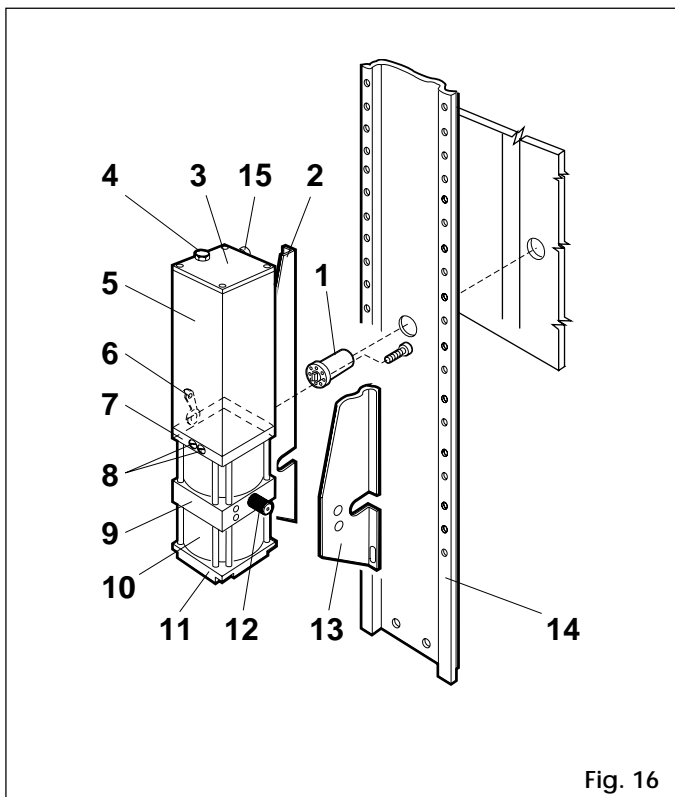

Fig. 16

- ① external release device (optional)
- ② side mounting bracket
- ③ upper flange
- ④ oil filler plug
- ⑤ oil tank
- ⑥ internal release lever
- ⑦ distribution flange
- ⑧ torque adjustment screws
- ⑨ central body for operator attachment
- ⑩ cylinder
- ⑪ lower flange
- ⑫ drive shaft
- ⑬ side mounting bracket
- ⑭ backplate
- ⑮ bleed screw

Table 1 Technical specifications of 593 operator

Power supply	230V~ (+6 -10 %) 50Hz
Absorbed power (W)	220
Duty cycle %	50
Oil type	FAAC XD 220
Oil quantity (l)	1
Motor winding thermal cutout	120° C
Anti-crushing system	bypass valve fitted as std.
Temperature range	-20 ÷ +55 °C
Housing protection	IP 55
Weight (kg)	10
Pump flow rate (l/min.)	0.75
Angular velocity (rpm)	1.54
Max. door weight (kg/m²)	15
Max torque (Nm)	400
Max. door height (m)	2.70 with 1 operator
Max. door weight (m)	3.5 with 1 operator
<b>Technical characteristics of electric motor</b>	
Speed (rpm)	1400
Power (W)	200
Current drawn (A)	1.2
Power supply	230V~ (+6 -10 %) 50Hz

### 1.1. MAXIMUM DUTY CYCLE CURVE

The curve allows the maximum working time (T) to be obtained as a function of duty cycle (F).

For example, the 593 operators can operate uninterruptedly at a duty cycle of 50%.

To ensure good operation, keep to the field of operation lying below the curve.

**Important:** The curve refers to a temperature of 24°C. Exposure to direct sunlight can result in a reduction in duty cycle to as low as 20%.

#### Calculating duty cycle

The duty cycle is the percentage of effective working time (opening + closing) with respect to the total cycle time (opening + closing + pause times).

It is calculated using the following formula:

$$\%F = \frac{Ta + Tc}{Ta + Tc + Tp + Ti} \times 100$$

where:

Ta = opening time

Tc = closing time

Tp = pause time

Ti = interval between one complete cycle and the next.

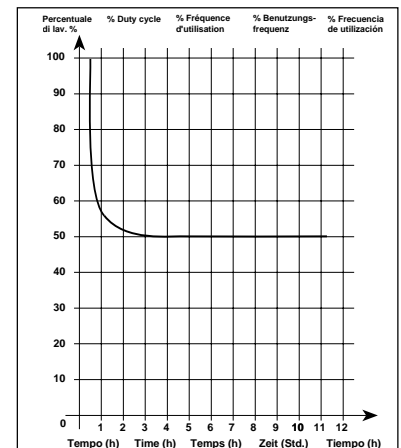

## 2. INSTALLATION LAYOUT

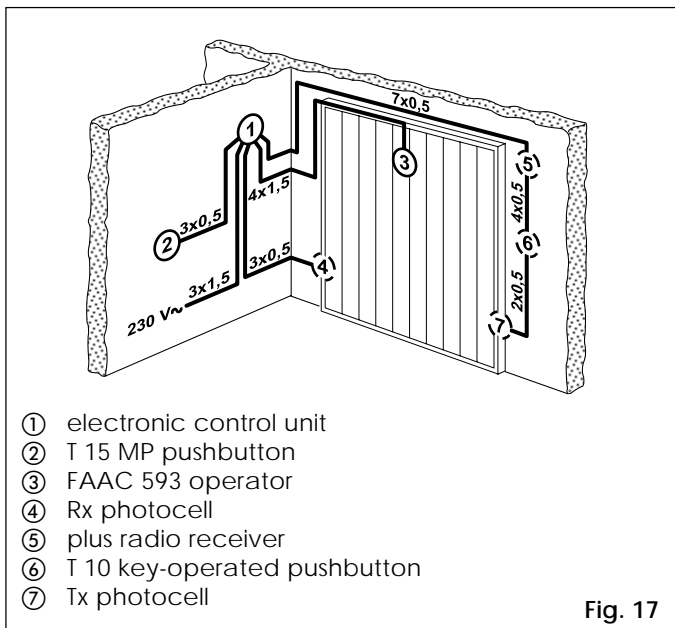

## 3. DIMENSIONS

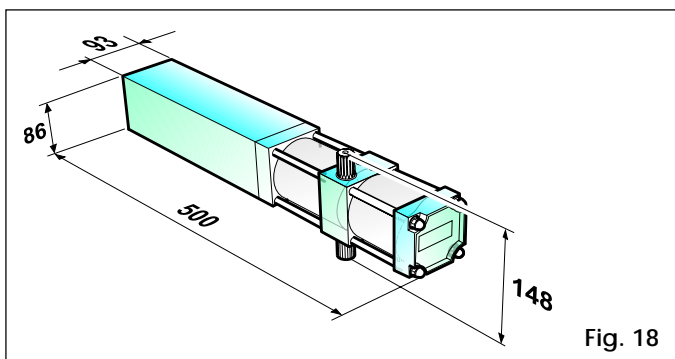

## 4. INSTALLATION

### 4.1. PRELIMINARY CHECKS

Make sure that the dimensions of the door are within the limits stated in the technical specifications. Make sure that the door operates smoothly and has no stiff points. If necessary, clean the tracks and lubricate them with a silicon based lubricant. Do not use grease. Check the condition of all door bearings and joints. Remove the manual door locks so that when the door is closed it will be locked only by the automation system. Make sure that there is a **230 Vac** power supply point in the garage, and that it is protected by an adequate residual current circuit-breaker.

The **FAAC 593** automation system is designed to operate various types of garage doors with counterweights. **Figs. 1, 2, and 3** show the most common types: canopy door, articulated panel, horizontal tracks. Either metal blocks or bricks can be used as counterweights, though some door manufacturers use springs instead of weights. Check in any case that the door pivots correctly when opening and closing.

### 4.2. INSTALLATION OF OPERATOR

Accessories of the **FAAC 593** are supplied in two versions:

- “Welded assembly”: welded telescopic arms, drive shafts, and mounting brackets.

- “Screw assembly”: all accessories feature screw-on attachment.

Straight or curved telescopic arms are available for both versions.

The present instructions refer to “screw assembly”.

### 4.3. POSITIONING OF TELESCOPIC ARMS

Ensure that there is a gap (**S** - **fig.5**) of at least **15 mm** between the existing cross bar and the frame. This is essential if straight telescopic arms are to rotate correctly as shown in **fig.8**.

If gap (**S**) is less than **15 mm**, the special curved telescopic arm must be used instead, and installed as shown in **fig.9**. Refer to **fig.4** to fix brackets (**D**) to the upright member as close as possible to the upper support of the existing cross bar. Fit the outer profiles of the arms. Respect maximum door dimensions as per the technical specifications and install either one operator (**FAAC 593**) at the centre of the door (**fig.6**) or two operators at the sides of the door (**fig.7**).

### 4.4. POSITIONING THE BACK PLATE / OPERATOR / DRIVE SHAFTS

The back plate (**Z**) features two holes (**M**) and (**N**) which allow for fixture to the upper cross bar of the door as indicated in **A** and **B** of **fig.4**.

In the case of door heights of less than **2100 mm**, fit the backplate on the upper cross bar by means of (**M**) (see **A**). With door heights above **2100 mm**, fit the backplate by means of (**N**) (see **B**, **fig.4**).

Drill two 6 mm holes (**U**) for backplate fixture onto the central reinforcement ribbing of the door (**fig.4**). If the door frame is not sufficiently sturdy (thin sheet) use nuts and bolts. Alternatively, use self-tapping screws.

Locate the point of rotation of the drive shaft at **10 cm** below the bottom pivot of the door’s own arm as shown in **figs. 8 and 9**.

Remove bleed screw (**F**) and secure the operator by means of mounting brackets (**S**) on the backplate as shown in **fig.4**. Disconnect the operator and open the garage door as indicated in **fig.12** and turn the operator drive gear in the direction of the arrow to the piston limit. Rotate though approx. 5° in the opposite direction.

Close the garage door and fit drive shafts (**T** - **fig.4**) over the operator drive gears and cut to size as shown in **figs. 6/7**. Fit bushings (**C**) and brackets (**L**) on the drive shafts and secure brackets (**L**) on the door reinforcement ribbing taking care to maintain correct alignment of the drive shafts.

**Straight telescopic arm:** refer to **fig.8** - **Curved telescopic arm:** refer to **fig.9**

Open the garage door and position the telescopic arm as indicated in **figs. 8 or 9**. Cut the **outer profile** at point **A**. Cut the **inner profile** of the telescopic arm at reference point **B**. **N.B.** Leave a gap of about 1 cm at the ends of both profiles. Insert the drive shafts (**T**) in the inner profile of the telescopic arm (**Q** - **fig.4**), already cut to size, and drill an 8 mm hole. Secure by means of an M8 bolt.

To ensure smooth door closing operation install a cushion pad (**T** - **fig.14**). Alternatively, to prevent garage door off-balance and ensure optimal operator functioning, construct and install an “L” bracket as shown in **fig.15**.

**4.5. ADJUSTING THE COUNTERWEIGHTS**

The weight of the counterweights must be increased to ensure smooth operation. If there is insufficient space to add to the existing counterweights, remove them and replace them with blocks of a higher specific weight. To adjust the weights, release the operator and move the door to half-open position (45°). The door should remain in balance.

**4.6. DOUBLE APPLICATION**

For garage doors from 3.50 to 5 m wide, two 593 operators must be used. The maximum permitted height is 3 m. Install following the same criteria as for a single motor (fig. 7).

**5. STARTUP**

**5.1. DIRECTION OF ROTATION**

1. Disconnect the electronic control unit from the power supply.
  2. Unlock the operator, and manually move the garage door to its half-open position (see section 6, manual operation).
  3. Relock the system (see section 6, manual operation).
  4. Reconnect the power supply.
  5. Send an OPEN command and check that the garage door opens correctly.
- N.B.** If the first OPEN impulse causes the garage door to close, invert the position of the black and brown wires on the electronic control unit.

**5.2. ADJUSTMENT OF OPERATION TIME**

Time the opening movement. On the electronic control unit, select an operation time that is a few seconds longer than that of the movement you have timed, in order to obtain optimal hydraulic locking efficiency.

**5.3. ADJUSTING TRANSMITTED TORQUE**

The 593 operator is fitted with an anti-crushing system to stop door movement whenever an obstacle is encountered during movement. Start garage door opening and adjust operator torque by means of the green screw (**V**, fig.4). Repeat the same operation for door closing by means of the red screw (**R**, fig.4). Correct adjustment is obtained when the door stops with a torque of approximately **15 kg** measured on the lower edge of the door. To increase torque, turn the screws clockwise; to reduce torque, turn screws anti-clockwise. When you have completed the adjustment operations, fit the bypass safety device on the operator by means of the relevant screws, as shown in the figure below.

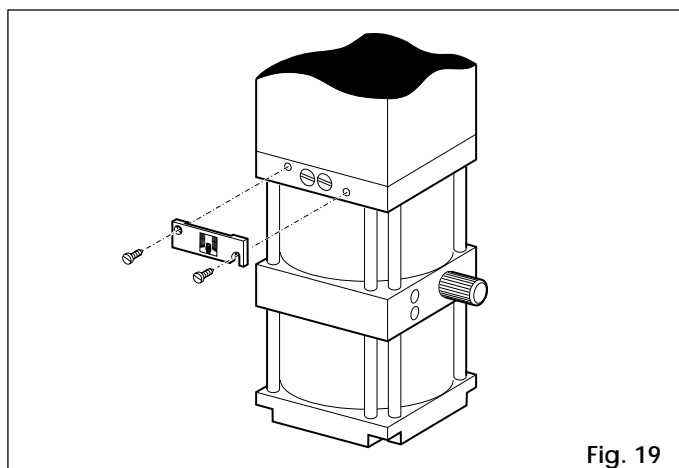

**5.4. TESTING THE AUTOMATED UNIT**

After completing installation, attach the danger warning labels between the transmission tubes and the telescopic arms (figs. 6-7). Carry out a careful functional check of the operator and all accessories connected to it. Give the customer the "User guide" and demonstrate how to use the operator correctly. Point out the potential danger zones of the automated unit.

**6. MANUAL OPERATION**

Should the need arise to actuate the garage door manually because of a power failure or malfunction, operate the unlocking lever device as shown in **fig. 20**. A customised key-operated emergency release can also be installed outside (**fig.21**) (optional).

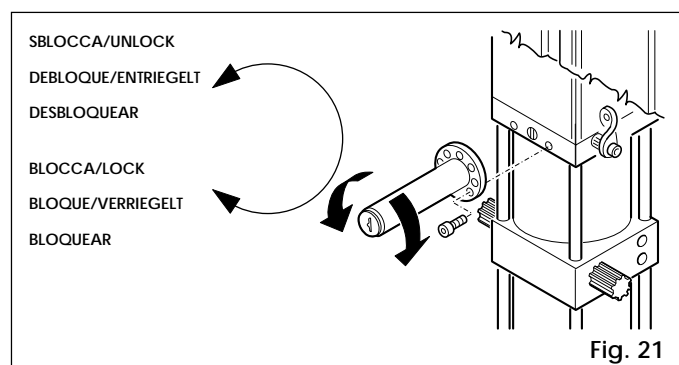
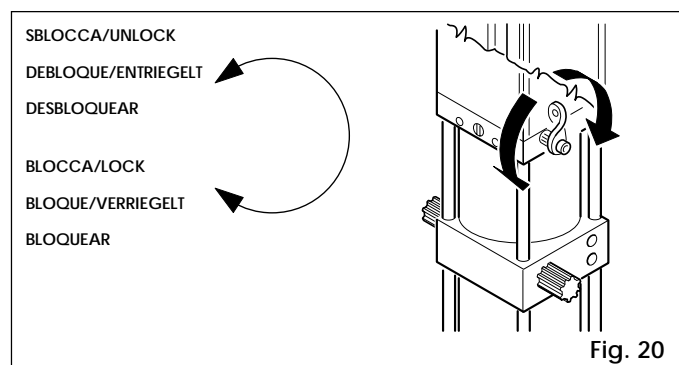

- Insert the key in the lock, and turn the key **anticlockwise** by 1 turn.
- Manually open or close the door.

**7. RETURNING TO NORMAL OPERATION**

To prevent an accidental impulse from actuating the garage door during this operation, before you restore normal operation, disconnect the system from the power supply.

lever (standard):

- turn the lever **clockwise** all the way.

customised key (optional):

- turn the key **clockwise** all the way;
- slowly turn the key **anticlockwise** up to the point where it can be extracted.

## 8. ACCESSORIES

### Limit switch kit

The limit switch kit makes it possible to stop the garage door in two specific positions.

It can be fitted on the FAAC 593 operator only if the 596 MPS card has been installed on it for this function. When this requirement has been met, proceed as follows:

1. Extract the shafts from the pinions, and mount the cams.
2. Remove the screws holding the operator onto the longitudinal sections, add the flat washers provided and mount the limit switch supports.
3. Tighten the screws, and fit the limit switches into their seats.
4. Open the garage door to the required point and turn cam A of microswitch FCA until the microswitch is activated.
5. Close the door to the required point and turn cam B of microswitch FCC until the microswitch is activated.
6. Tighten the self-tapping screws on the cams.

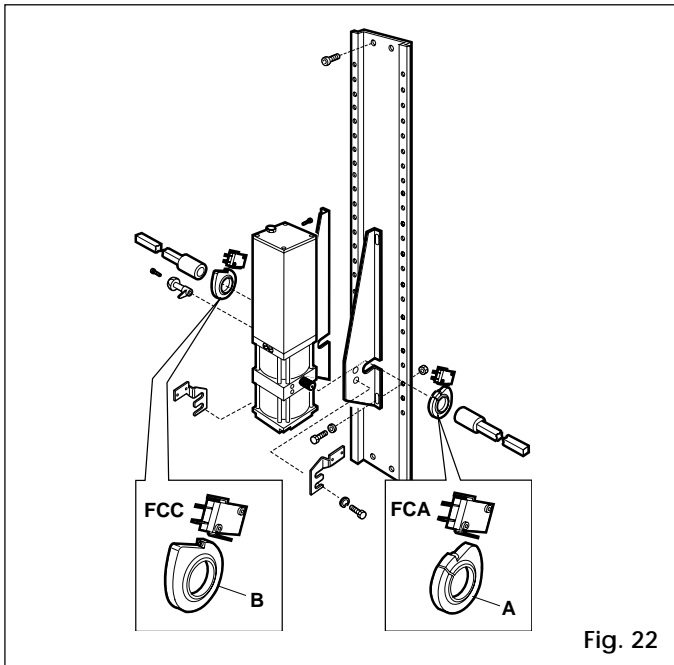

Fig. 22

### External release device with customised key (Figs. 10-11-23)

The release device with customised key makes it possible to actuate the garage door from the outside in case of a malfunction or breakdown.

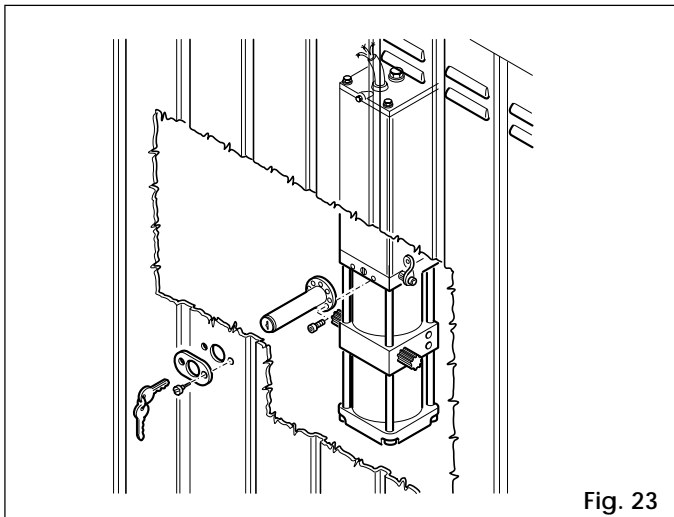

Fig. 23

## 9. MAINTENANCE

When performing maintenance always check that the bypass screws are set correctly, that the system is balanced and that the safety devices operate correctly.

### 9.1. TOPPING UP WITH OIL

Check periodically the quantity of oil inside the tank.

For medium/low duty cycles a yearly check is sufficient; for more severe operation it is advisable to check every 6 months.

The oil level must not be lower than the index line.

To top up, unscrew the filler cap (fig. 16) and pour in oil up to the correct level.

Use exclusively FAAC XD 220 oil.

### 9.2. BLEEDING AIR FROM HYDRAULIC CIRCUIT

If the beam moves in an irregular manner, this may be due to the presence of air in the hydraulic circuit.

If it is necessary to bleed the air, proceed as follows:

- 1) Check that the breather screws have been removed (fig. 16).
- 2) Disassemble the lateral drive shafts from the operator.
- 3) Set an operating time of about 1 minute on the electronic control unit.
- 4) Activate the operator electrically so that it turns to the end of its travel in both directions of rotation.
- 5) Repeat this operation several times if necessary.
- 6) Follow the installation instructions to reassemble.

## 10. REPAIRS

For repairs, contact an authorised FAAC Service Centre.

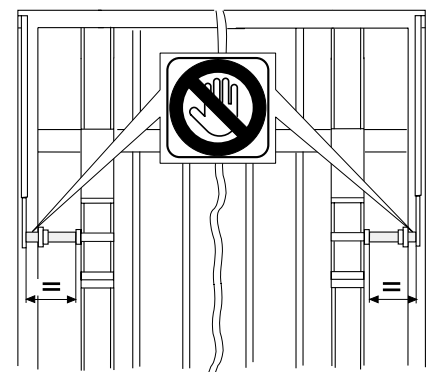
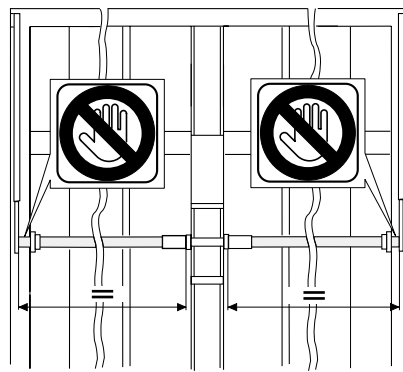
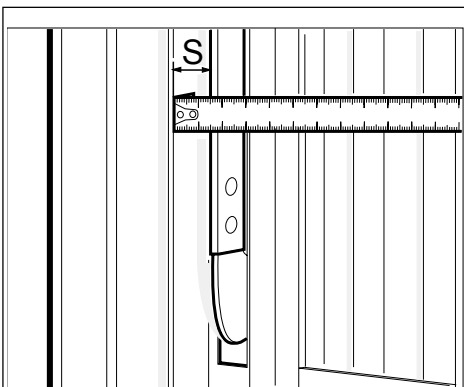
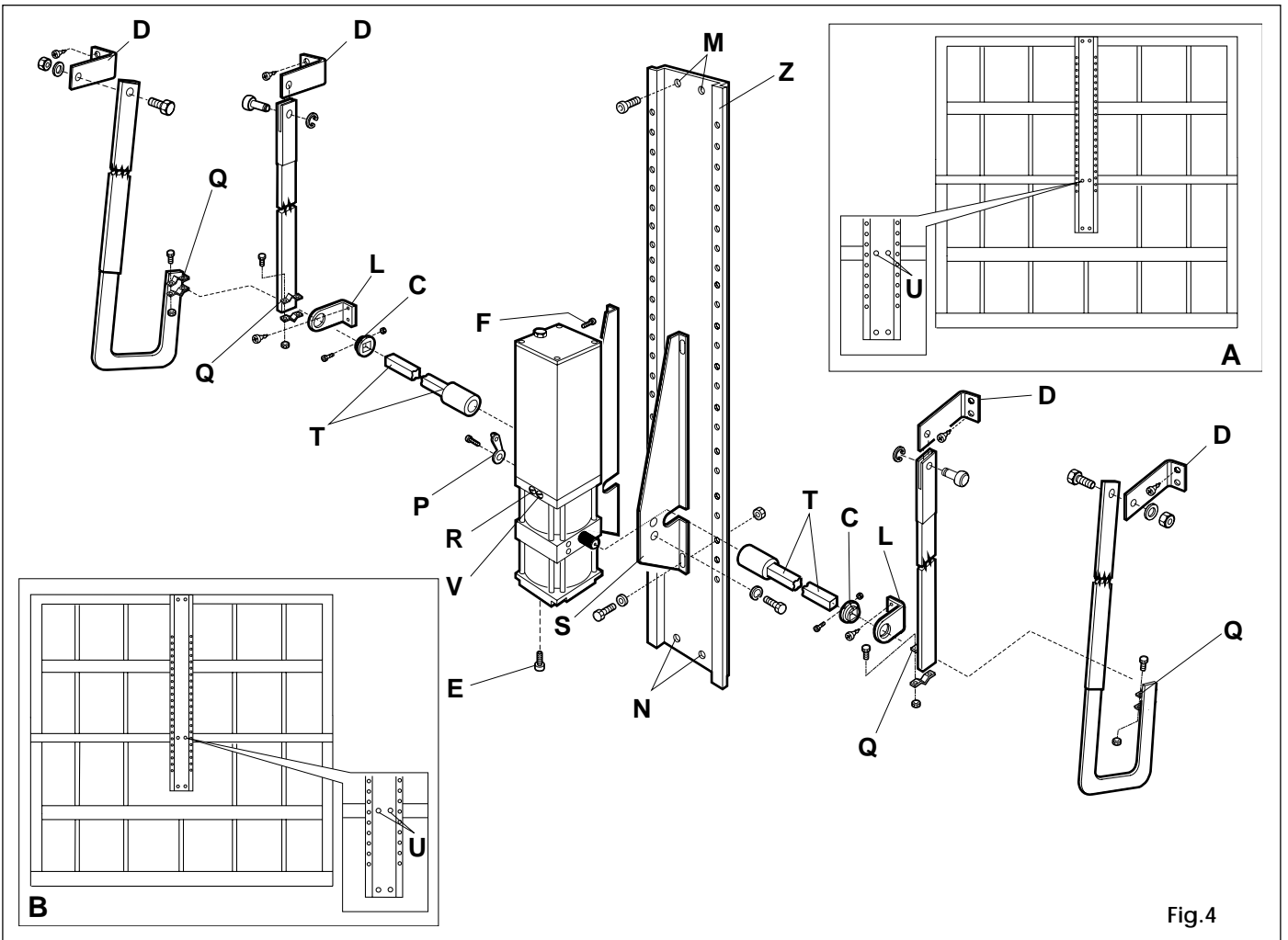
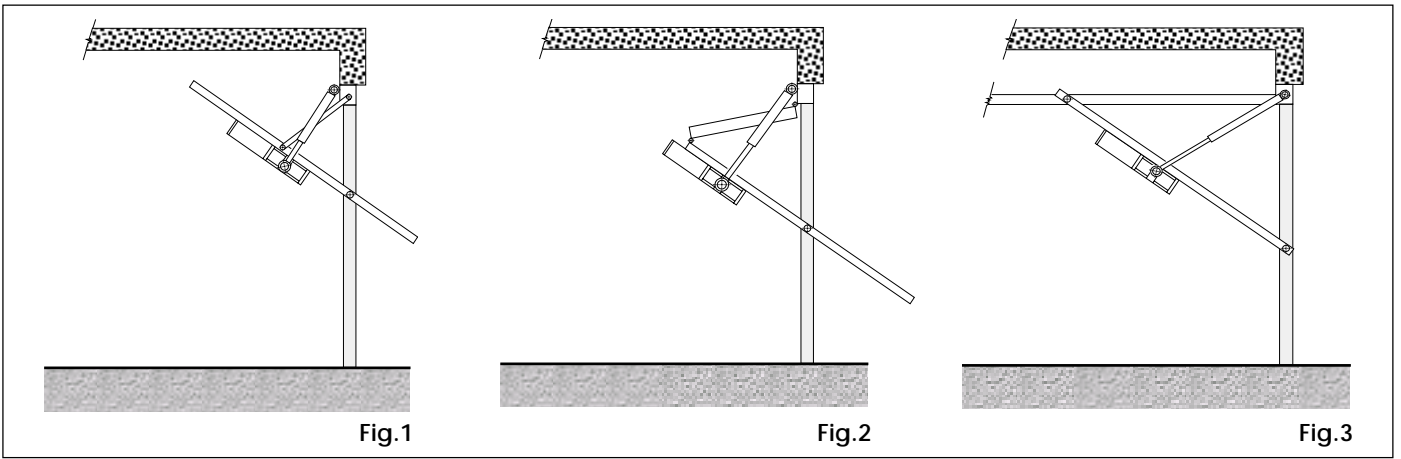



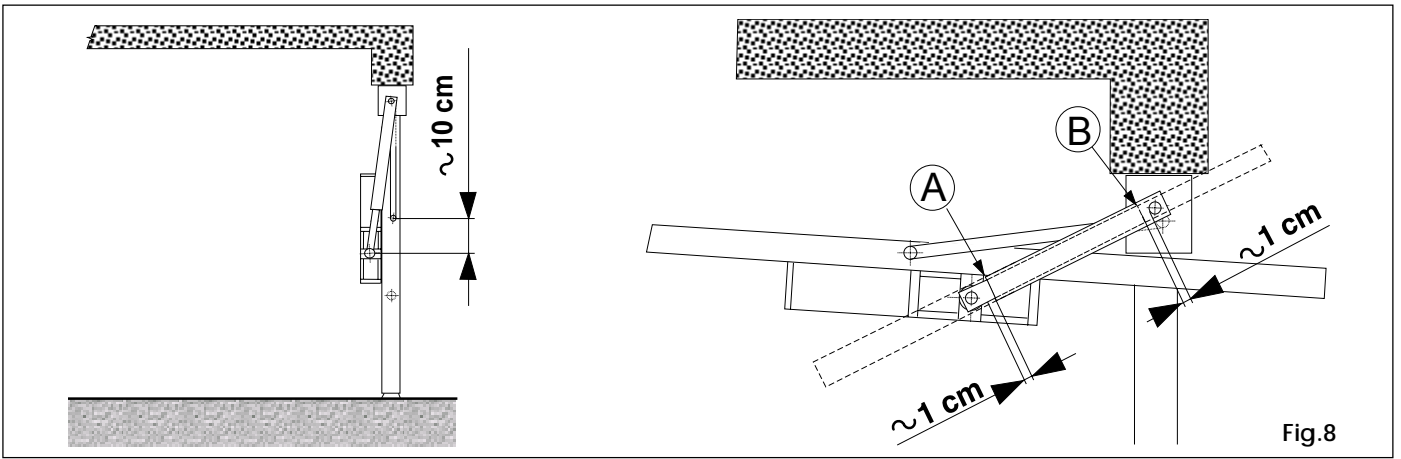

Fig.8

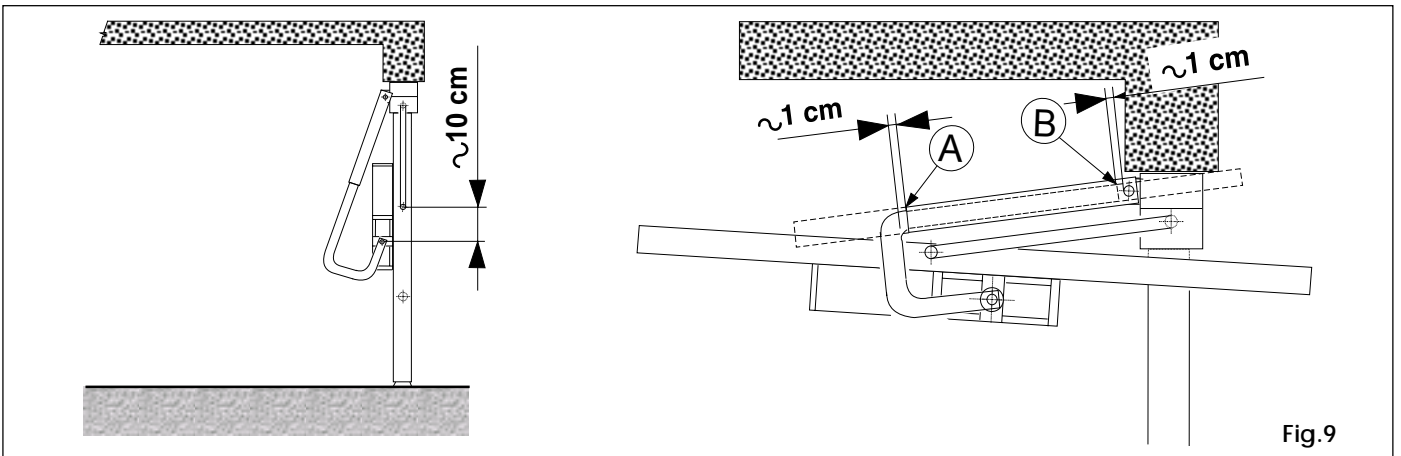

Fig.9

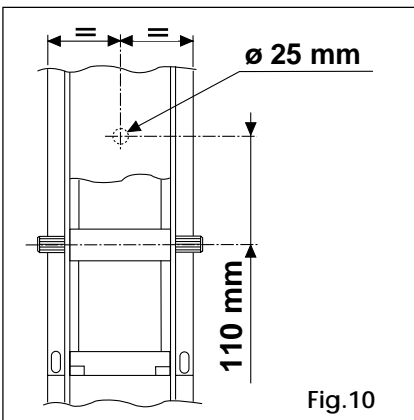

Fig.10

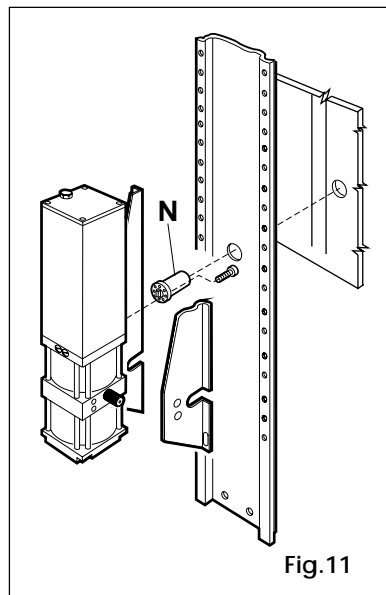

Fig.11

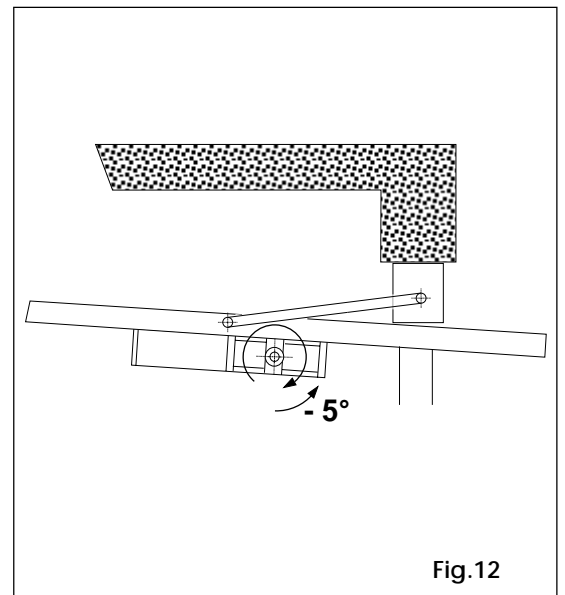

Fig.12

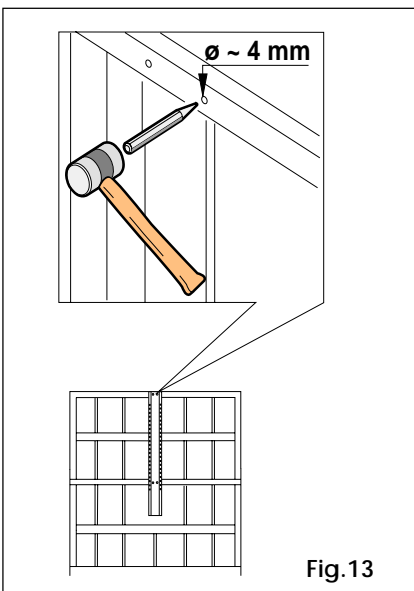

Fig.13

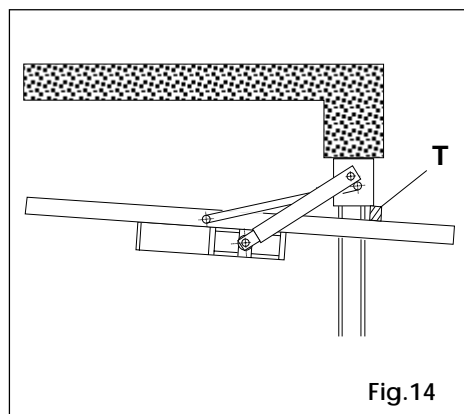

Fig.14

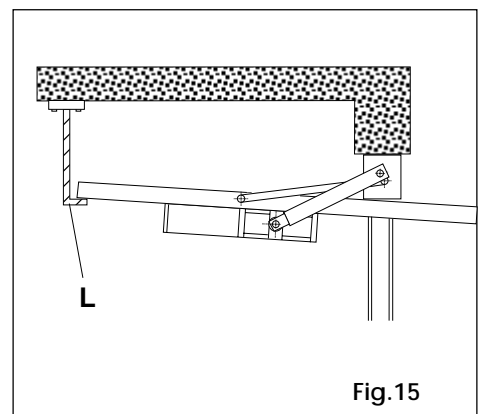

Fig.15

## END-USER GUIDE

### THE 593 AUTOMATION SYSTEM

Read the end user guide carefully before using the product and keep it in a safe place for future reference.

#### GENERAL SAFETY INSTRUCTIONS

If correctly installed and operated, the 593 automation system ensures a high level of safety.

However, some simple rules should be followed to avoid accidents:

- Do not pass underneath the door while it is moving: wait until it is completely raised.
- Do not remain stationary under the door.
- Do not stand in the vicinity of the automation system or allow anyone else, especially children, to do so, and do not place objects in the vicinity of the automation system. This is particularly important during operation.
- Keep remote controls or any other control device out of the reach of children, to prevent them from accidentally operating the automation system.
- Do not allow children to play with the automation system.
- Do not deliberately obstruct the movement of the door.
- Do not attempt to operate the door manually without first unlocking it.
- In the event of a malfunction, unlock the door to allow access and call a qualified technician for service.
- After manual operation, disconnect the electrical power supply from the system before returning to normal operation.
- Do not make any modifications to components belonging to the automation system.
- Do not attempt to perform any repair work or tamper with the automation system. Call qualified personnel for repairs.
- At least once every six months, have the automation system, the safety devices and the earth connection checked by a qualified technician.

#### DESCRIPTION

The 593 automation system is an operator for counterbalanced up-and-over doors. It is ideal for controlling vehicle access areas up to 5 metres wide (application with double operator) and with medium transit frequencies.

Door operation is controlled by an electronic control unit mounted in an enclosure which assures adequate protection against atmospheric agents and can be fitted inside the garage.

The normal position of the door is closed in a vertical position. When the electronic control unit receives an opening command from the remote radio control or any other control device, it activates the hydraulic system and causes the door to rotate upwards by 90° to the horizontal position, thereby allowing access.

If automatic operation has been selected, the door closes automatically after the selected pause time.

If semiautomatic operation has been selected, a second impulse must be sent to close the door.

An open command given while the door is closing causes the door to reverse direction of movement.

A stop command (if available) stops movement at any time.

For detailed information on door operation in the various operating modes, contact the installation technician.

The automation systems may be equipped with safety devices (photocells) that prevent the door from closing when they are darkened by an obstacle.

The 593 automation system is fitted as standard with an anti-crushing safety device that limits the torque transmitted to the door.

The hydraulic system ensures that the door can be locked in any position.

The door can be opened manually only after operating the unlocking device.

#### MANUAL OPERATION

If the door must be operated manually because of a power failure or malfunction, use the unlocking device as follows.

Lever release device (see fig. 1)

External key release device (see fig.2)

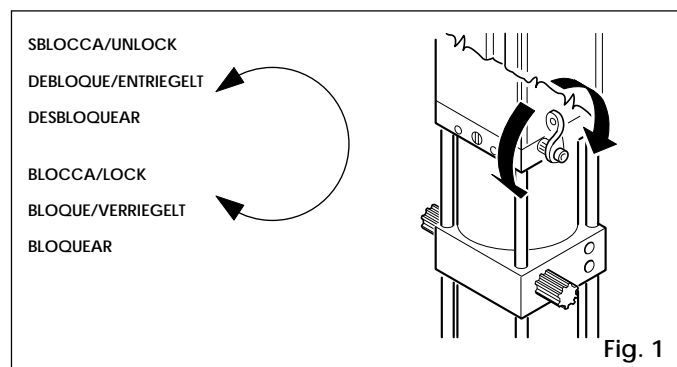

Fig. 1

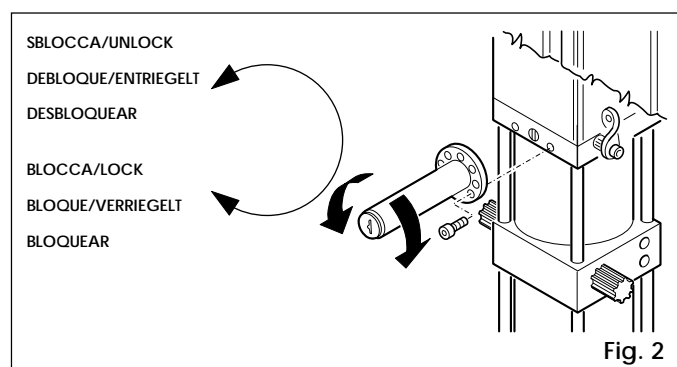

Fig. 2

- Insert the key in the lock and turn **anticlockwise** by one turn.
- Open or close the door manually.

#### RETURNING TO NORMAL OPERATION

To prevent an accidental impulse from activating the door during this operation, before returning to normal operation, turn off the system's electrical power supply.

Lever release device (see fig. 1)

External key release device (see fig.2)

- turn the key **clockwise** until it stops.
- turn the key **anticlockwise** very slowly to the point where it can be removed.



Le descrizioni e le illustrazioni del presente manuale non sono impegnative. La FAAC si riserva il diritto, lasciando inalterate le caratteristiche essenziali dell'apparecchiatura, di apportare in qualunque momento e senza impegnarsi ad aggiornare la presente pubblicazione, le modifiche che essa ritiene convenienti per miglioramenti tecnici o per qualsiasi altra esigenza di carattere costruttivo o commerciale.

The descriptions and illustrations contained in the present manual are not binding. FAAC reserves the right, whilst leaving the main features of the equipments unaltered, to undertake any modifications it holds necessary for either technical or commercial reasons, at any time and without revising the present publication.

Les descriptions et les illustrations du présent manuel sont fournies à titre indicatif. FAAC se réserve le droit d'apporter à tout moment les modifications qu'elle jugera utiles sur ce produit tout en conservant les caractéristiques essentielles, sans devoir pour autant mettre à jour cette publication.

Die Beschreibungen und Abbildungen in vorliegendem Handbuch sind unverbindlich. FAAC behält sich das Recht vor, ohne die wesentlichen Eigenschaften dieses Gerätes zu verändern und ohne Verbindlichkeiten in Bezug auf die Neufassung der vorliegenden Anleitungen, technisch bzw. konstruktiv/kommerziell bedingte Verbesserungen vorzunehmen.

Las descripciones y las ilustraciones de este manual no comportan compromiso alguno. FAAC se reserva el derecho, dejando inmutadas las características esenciales de los aparatos, de aportar, en cualquier momento y sin comprometerse a poner al día la presente publicación, todas las modificaciones que considere oportunas para el perfeccionamiento técnico o para cualquier otro tipo de exigencia de carácter constructivo o comercial.

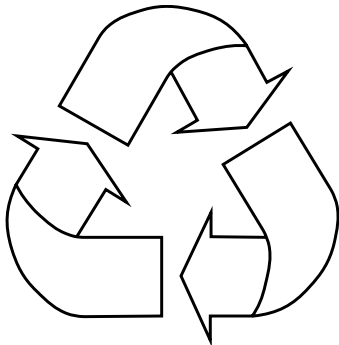

**FAAC per la natura**

- La presente istruzione è realizzata al 100% in carta riciclata.
- Non disperdete nell'ambiente gli imballaggi dei componenti dell'automazione bensì selezionate i vari materiali (es. cartone, polistirolo) secondo prescrizioni locali per lo smaltimento rifiuti e le norme vigenti.

**FAAC for the environment**

- The present manual is produced in 100% recycled paper
- Respect the environment. Dispose of each type of product packaging material (card, polystyrene) in accordance with the provisions for waste disposal as specified in the country of installation.

**FAAC der Umwelt zuliebe**

- Vorliegende Anleitungen sind auf 100% Altpapier gedruckt.
- Verpackungstoffe der Antriebskomponenten (z.B. Pappe, Styropor) nach den einschlägigen Normen der Abfallwirtschaft sortenrein sammeln.

**FAAC écologique**

- La présente notice a été réalisée 100% avec du papier recyclé.
- Ne pas jeter dans la nature les emballages des composants de l'automatisme, mais sélectionner les différents matériaux (ex.: carton, polystyrène) selon la législation locale pour l'élimination des déchets et les normes en vigueur.

**FAAC por la naturaleza.**

- El presente manual de instrucciones se ha realizado, al 100%, en papel reciclado.
- Los materiales utilizados para el embalaje de las distintas partes del sistema automático (cartón, poliestireno) no deben tirarse al medio ambiente, sino seleccionarse conforme a las prescripciones locales y las normas vigentes para el desecho de residuos sólidos.



**FAAC**

FAAC S.p.A.  
Via Benini, 1  
40069 Zola Predosa (BO) - ITALIA  
Tel.: 051/6172411 - Tlx.: 521087  
Fax: 051/758518

Timbro del Rivenditore:/Distributor's Stamp:/Timbre de l'Agent:/ Fachhändlerstempel:/Sello del Revendedor: